

JVC

SERVICE MANUAL

MODEL

CD-1636/C

CD-1635 Mark II

(CD-1635-2A/B/E/U)

PORTABLE STEREO CASSETTE DECK



Index

	Page		Page
Specifications	2	Main Amp.	16
Features	3	ANRS	20
Controls and Connections	3	Check	23
New Techniques	4	Muting	23
Sen Alloy Head	4	Mic Jack	23
Coreless Motor	5	Switch	24
Super ANRS Recording and Playback	6	Mechanical Components	27
Main Parts Removing & Replacement	9	Enclosure Assembly	30
Enclosure Assembly	9	Electrical Parts Except Circuit Board Parts	32
Electric Parts	9	Wiring	34
Mechanical Parts	10	Standard Schematic Diagram	35
Main Adjustments	12	Accessories	36
Block Diagram	14	Packing	37
Circuit Board Parts	16		

Specifications

Type	: Portable stereo cassette deck	Input jacks	: Mic jack; 2 Max. sensitivity; 0.14mV (-75dBs) Matching impedance; 200Ω~10kΩ
Track system	: 4-track, 2-channel		
Cassettes	: C-30, C-60, C-90		
Tape speed	: 4.8cm/sec		
Frequency response	:		
Chrome *1	25~18,000Hz (Nominal) 30~16,000Hz (Typical)		
Regular *2	25~17,000Hz (Nominal) 30~15,000Hz (Typical) Supasses DIN 45500 *1 TP-18 or Equivalent *2 QP-12 or Equivalent	Output jacks	: Output jack; 2 Output level; 500mV (fixed) Output impedance; 2kΩ Matching load impedance; 50kΩ or more
Signal-to-Noise ratio	: 54dB (JIS) The S/N is improved by 5dB at 1kHz and by 10dB above 5kHz with ANRS on. 62dB with ANRS (DIN 45500, weighted)	Recording connector	: (REC/PB) Min. input level; 11mV (-37dBs) Input impedance; 9.2kΩ Output level; 500mV Output impedance; 2kΩ Matching load impedance; 50kΩ or more
Effect of Super ANRS (Normal tape)		Speaker	: Output; 1.2W (distortion, 10%) Impedance; 4Ω Diameter; 10cm
Improvement of		Power supply	: DC 9V (U1 x 6) External DC power; 8~16V AC power; 120V, 60Hz for CD-1636/C 240V, 50Hz for CD-1635-2A/B 220V, 50Hz for CD-1635-2E 100V, 110~120V, 200V 50/60Hz for CD-1635-2U
Signal-to-Noise ratio	: the same as with ANRS		
Improvement of			
frequency response	: 0VU recording; 6dB at 10kHz +5VU recording; 12dB at 10kHz		
Improvement of			
distortion	: 0VU recording; 3% or less at 10kHz +5dB recording; 3% or less at 10kHz		
Wow and flutter	: 0,08% (WRMS) 0,20% (DIN 45511)		
Crosstalk	: 65dB		
Harmonic distortion	: 1.2% (standard tape)		
Bias	: AC bias (95kHz)		
Erase	: AC erasure		
Heads	: 2 heads SA head for recording/playback and ferrite head for erasure		
Motor	: DC coreless motor		
Recording time	: 2 x 30 minutes with the C-60 cassette		
Fast wind time	: 90 sec (with the C-60 cassette) per track		
Rewind time	: 90 sec (with the C-60 cassette) per track		
Semiconductors	: IC; 5, Transistors; 35, Diodes; 29, SCR; 1		
		Power consumption	: 9W
		Battery life	: Approx. 12 hours of continuous recording (on super type batteries) Approx. 5 hours of continuous recording (on regular type batteries)
		Dimensions	: 14-1/4(width) x 3-7/8(height) x 9-1/2(depth) in.
		Weight	: 11.5 lbs (including 6 batteries)

Design and specifications are subject to change without notice.

Features

- * High Performance
- * Power-saving Design
- * Coreless Motor
- * Built-in ANRS (U.S. Pat. 375 7254 and 376 9612) and Super ANRS
- * Sen-alloy Head
- * Full Auto Stop
- * Tape Select Switches

- * High-linearity Amplifier
- * High-precision Mechanisms
- * Input Select Switch and Microphone Attenuator
- * Master Recording Volume Control
- * External DC Power Connection Terminal
- * Built-in Large Speaker
- * REC MODE Select Switch
- * Front Panel Protectors

Controls and Connections

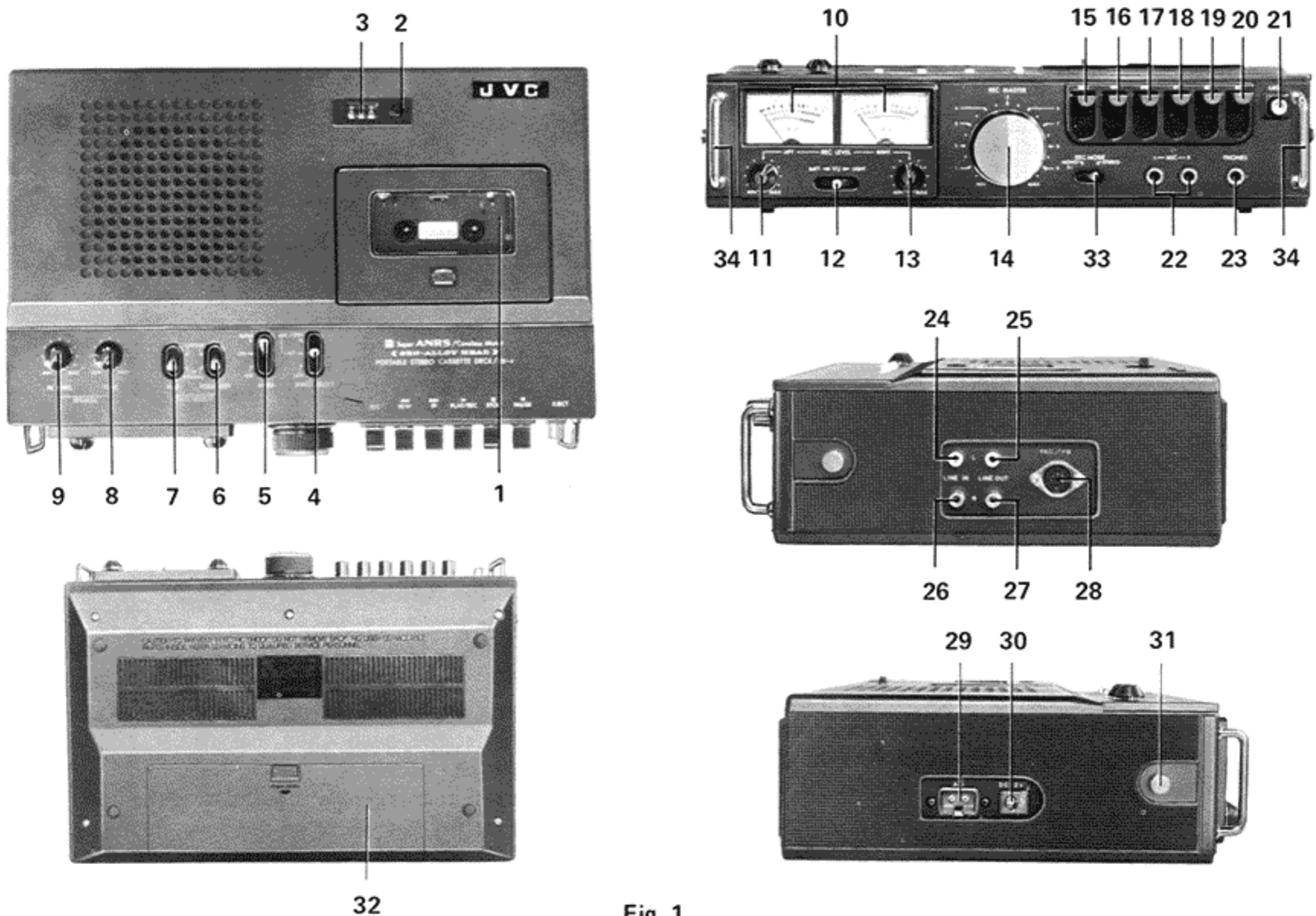

Fig. 1

- | | |
|--|--|
| <ul style="list-style-type: none"> 1 Cassette door 2 Reset button 3 Tape counter 4 Input selector switch [INPUT SELECT] 5 ANRS switch [ANRS] 6 Equalizer switch [EQUALIZER] 7 Bias switch [BIAS] 8 Speaker tone control [TONE] 9 Speaker volume control [PB LEVEL] 10 Level meters 11 Left recording level control [REC LEVEL] 12 Check switch [batt/VU light] 13 Right recording level control [REC LEVEL] 14 Master recording volume control [REC MASTER] 15 Record button [REC] 16 Rewind button [REW] 17 Fast forward button [FF] | <ul style="list-style-type: none"> 18 PLAY/REC button [PLAY/REC] 19 STOP button [STOP] 20 PAUSE button [PAUSE] 21 EJECT button [EJECT] 22 Microphone jacks [L-MIC-R] 23 Headphone jack [PHONES] 24 Left auxiliary input jack [LINE IN] 25 Left auxiliary output jack [LINE OUT] 26 Right auxiliary input jack [LINE IN] 27 Right auxiliary output jack [LINE OUT] 28 Record/playback DIN jack [REC/PB] 29 AC input terminal [AC] 30 DC input terminal [DC 12V] 31 Shoulder belt holder 32 Battery cover 33 REC MODE select switch 34 Front panel protectors |
|--|--|

CD-1635-2, CD-1636
No. 4145

New Techniques

Sen Alloy Head

Features of the SEN-ALLOY head

1. Highly resistant to wear and long in service life
The SEN-ALLOY head has a service life as long as that of a ferrite head because the area of it which comes into contact with the tape is made of SENDUST ALLOY with a hardness comparable to that of ferrite. Additionally, unlike ferrite, SENDUST ALLOY is not subject to chipping cracking, so that a long life and stable performance are assured.

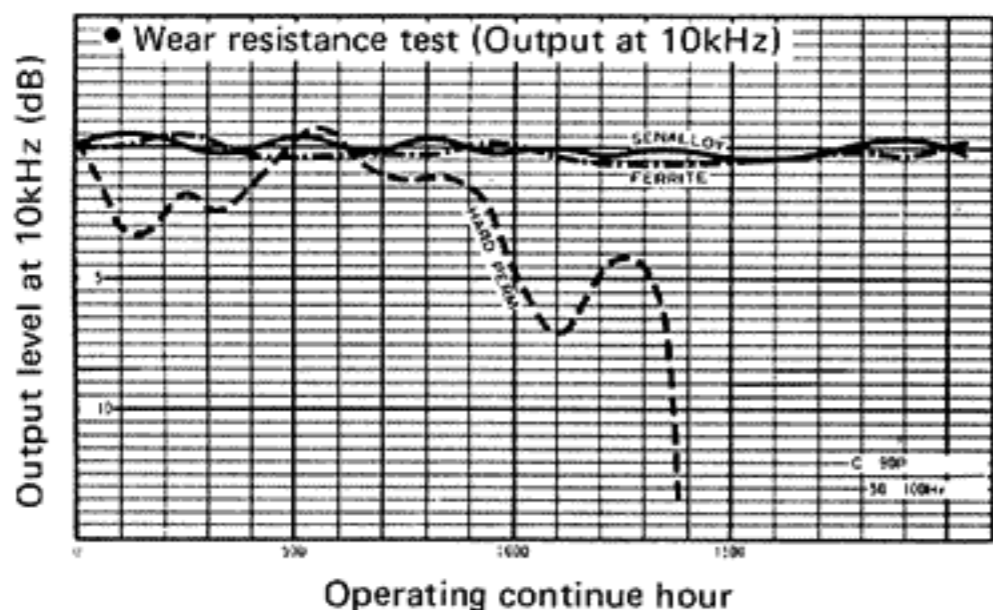

Fig. 2

2. Excellent overall sound quality
Because the core on which the coil is wound is made from permalloy and the area which comes into contact with the tape is made from SENDUST ALLOY, high gap accuracy can be assured as with ferrite heads, so that frequency response at high frequencies is sufficiently extended. As the maximum flux density of the SENDUST ALLOY used for the gap section is much higher than that of ferrite and higher than that of permalloy, distortion of high level signals in recording is reduced and linearity is improved. This gives big advantages over ferrite heads when using the new high performance tape and chrome tape. From the viewpoint of overall sound quality, the sound is not so hard as that from ferrite heads; it is natural, high resolution sound like from permalloy heads.

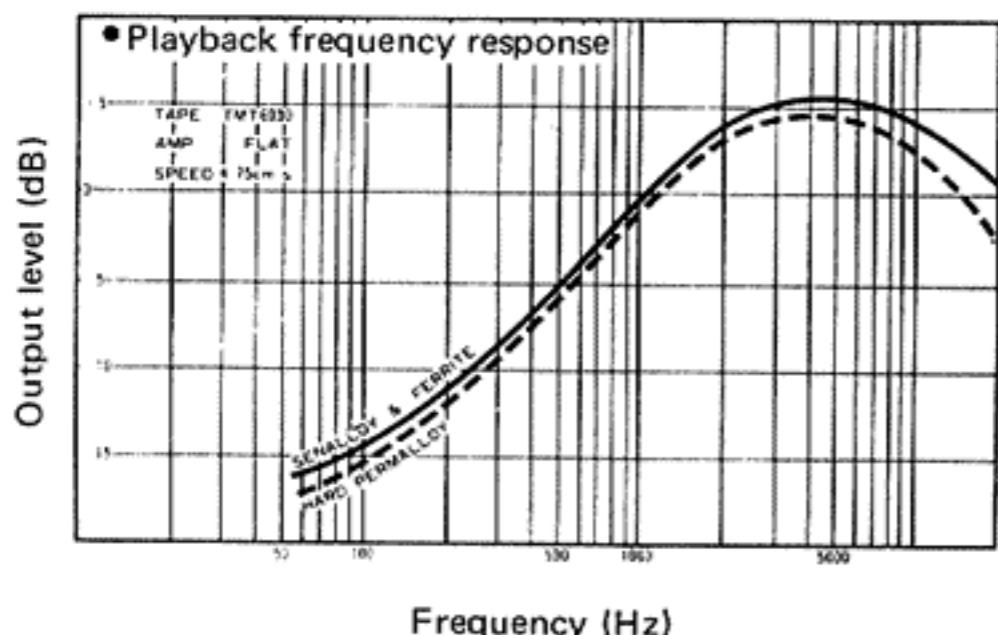

Fig. 3

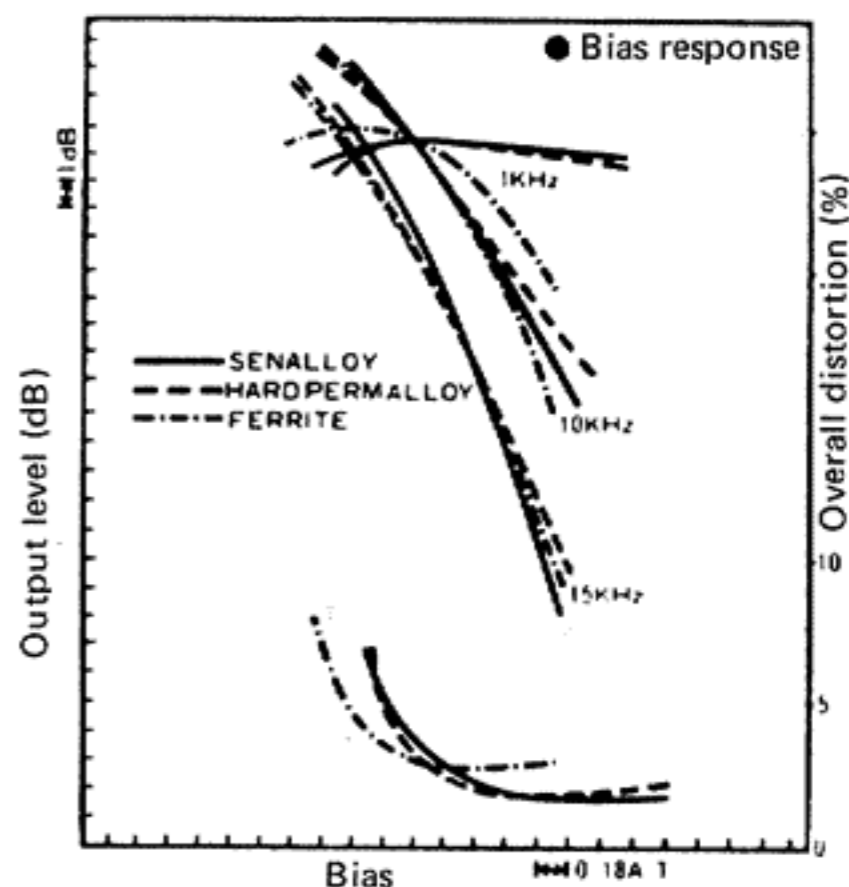

Fig. 4

3. No detectable noise
Like the permalloy head, the SEN-ALLOY head is made entirely from metal. This eliminates Barkhausen noise, one of the principal drawbacks of ferrite heads which results from non-uniform crystallization and large magnetic domains (units of molecules to be magnetized). Tape contact noise has been reduced to the same level as with permalloy heads.
4. Characteristics stable against temperature fluctuations
As the Curie temperature of SENDUST ALLOY — that is, the temperature at which it loses its magnetic properties — is 500° C, much higher than the 100° C or so of ferrite and relatively higher than the 450° C of permalloy, the characteristics of the SEN-ALLOY head are highly stable, even when the temperature where it is used fluctuate widely.
5. Magnetization characteristic suitable as the head material
The higher the coercivity of the core, the more difficult is it for it to lose its magnetization once it is magnetized. This is the reason when heads become magnetized. As time passes, the head becomes more and more magnetized and this is heard as noise in playback. As the coercivity of SENDUST ALLOY used in the SEN-ALLOY head is about half of that of ferrite, its magnetization characteristic is almost the same as that of permalloy. Because of this, there is no need to demagnetize the head so often and trouble-free cassette playback is long assured.

SEN-ALLOY head construction

The coil is wound on a laminated permalloy core and at the end of this core, where the tape comes into contact, a chip of SENDUST ALLOY whose hardness is comparable to that of ferrite and whose magnetic properties are superior to those of permalloy is bonded at a high temperature.

Sen-alloy head construction

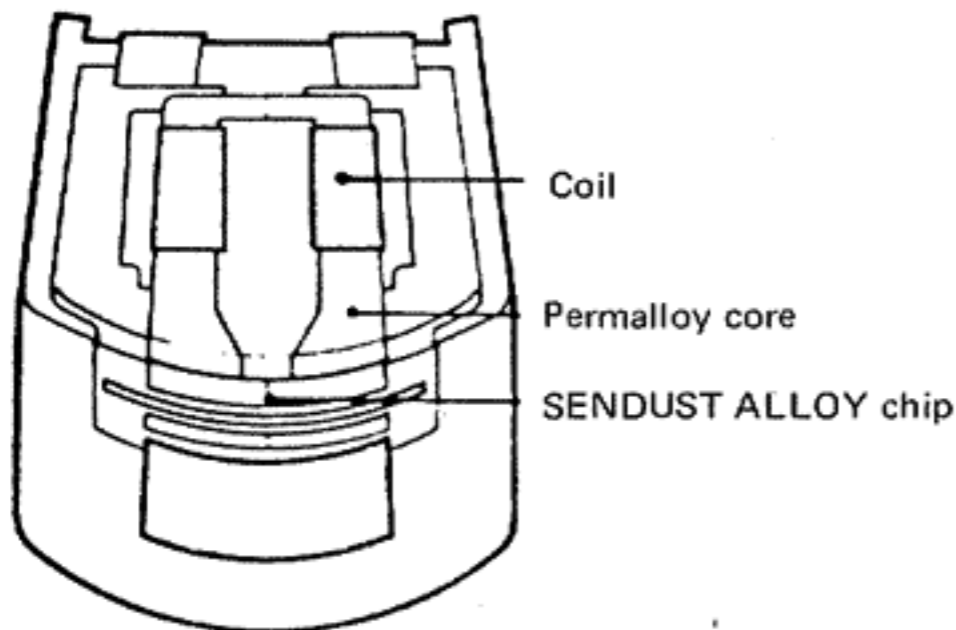

Fig. 5

Comparison table of the characteristics of typical heads

	Sen-alloy	Ferrite	Permalloy
Wear resistance, partial wear resistance — Is head surface sufficiently hard?	⊙	⊙	△
Frequency response — Can gap accuracy be guaranteed?	⊙	⊙	○
Distortion in recording — Is maximum flux density high?	⊙	△	○
Noise — Is it free from noise characteristic of core material?	⊙	△	⊙
Magnetization — Is coercivity of core material low?	⊙	△	⊙
Overall sound quality	⊙	△	○

Fig. 6-1

Photos comparing wear resistances of typical heads

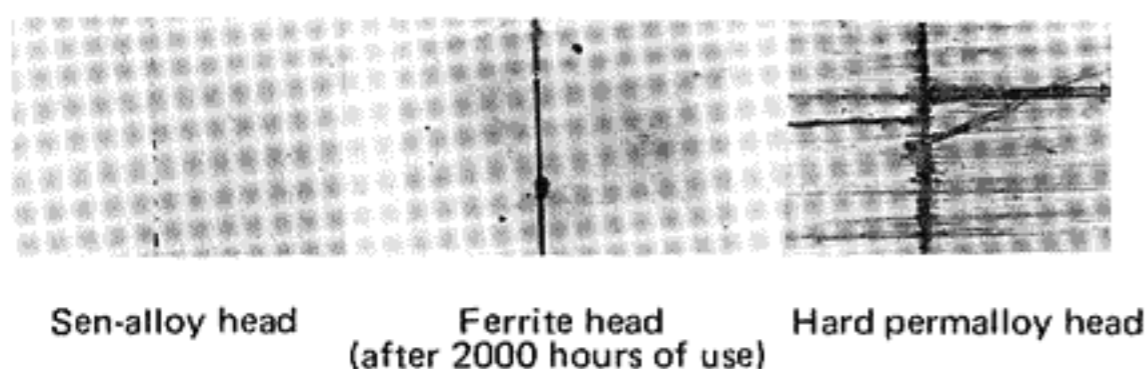

Fig. 6-2

Coreless Motor

The Coreless Motor with its high efficiency, low inertia, high reliability and long service life was developed for use in data recorders, measuring equipment and precision machinery. It is a d.c. servomotor with superb accuracy and reliability.

Construction of Coreless Motor

A conventional d.c. motor consists of a solid rotor surrounded by a coil and ring-shaped magnet. The difference between the Coreless Motor and conventional motor can be seen from the following diagram. The stator is in the center and this is surrounded by the cup-shaped rotor which is a coil. The shaft runs through the center of this cup.

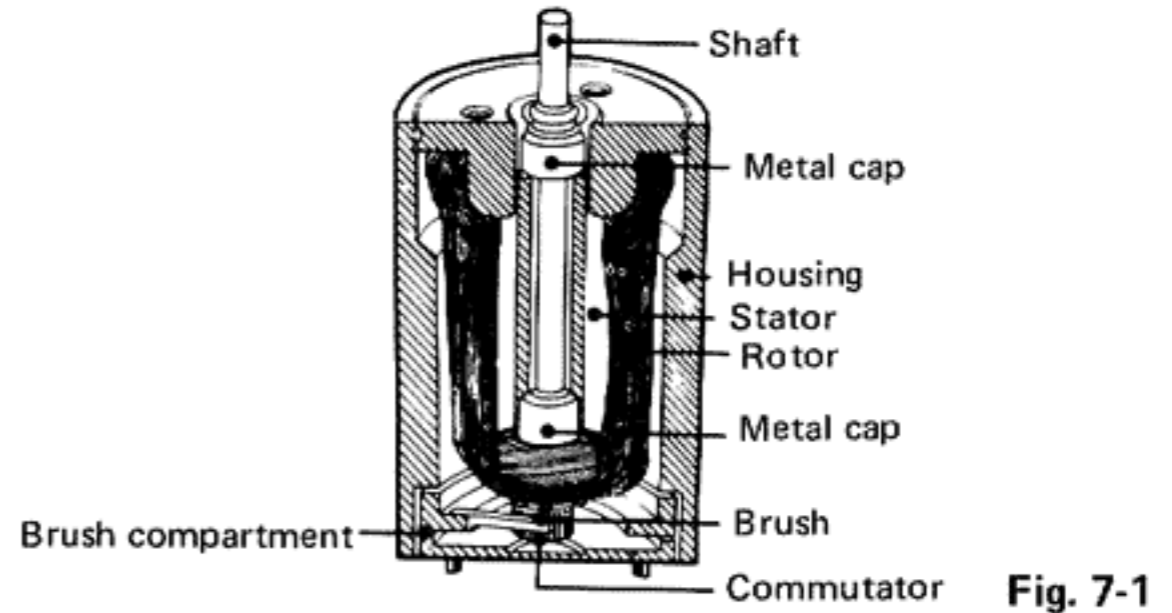

Fig. 7-1

Features

1. Core loss which is a drawback of the conventional motor is eliminated because of the construction, with the rotor being a coil without a core. Good starting and efficient running are possible because, by enlarging the magnetic area and increasing the number of windings, the magnetic flux density is greater than in a conventional motor.
2. The rotor is light and has a lower moment of inertia. It responds more rapidly to changes in driving torque, following control signals more precisely.
3. The inductance of the coil is low, the reactance voltage developed during rectification is low and the neutral point varies less, so that sparking between the commutator and brushes is minimized. With less sparking, noise is reduced, brushes have a longer service life and stability is improved; consequently the overall life of the motor is lengthened.
4. The motor revolves smoothly with stable speed because the commutator is divided into seven segments or individual coils while the conventional d.c. motor has three coils.

Motor characteristics — comparison curves

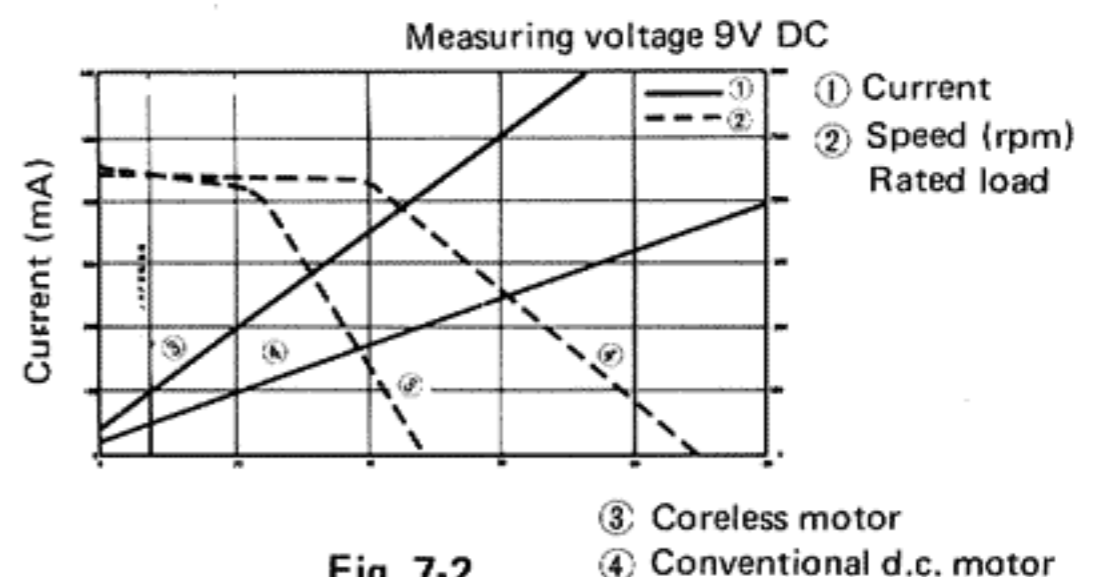

Fig. 7-2

Super ANRS Recording and Playback

1. What is Super ANRS

Super ANRS is an extension of ANRS, vastly improving the linearity of cassette tape at high frequencies. In addition to eliminating tape hiss.

Fig. 8 shows the relationship between signal levels in recording and playback. As you can see, when the frequency is 1kHz this relationship is linear up to almost +10dB whereas, when the frequency is 10kHz it is linear only to slightly more than -10dB. Fig. 9 shows frequency response curves for different signal levels. As the level of the signal rises, the linearity ceases at lower frequencies. In most kinds of music, however, high frequency components around 10kHz are at a lower level than low and middle frequency components. When the music is recorded at around 0VU, the high frequency components are usually recorded at -30dB or -20dB and so they are recorded without any attenuation.

However, there are passages where the insufficient linearity and dynamic range make themselves felt — music dominated by cymbals, the clapping of hands and certain vocal sounds. The highs are not reproduced as clearly and powerfully as in the original performance.

Recent improvements in cassette sound, in tapes, circuitry and heads, have raised its level almost to that of open-reel equipment. But, because of their lower tape speed, narrower track width and subsequent lower signal strength, cassette decks are still inferior to open-reel decks in linearity and S/N at high frequencies. The problem of S/N has been solved by ANRS and Dolby*, but the problem of linearity and dynamic range remained until now, with the advent of JVC's Super ANRS.

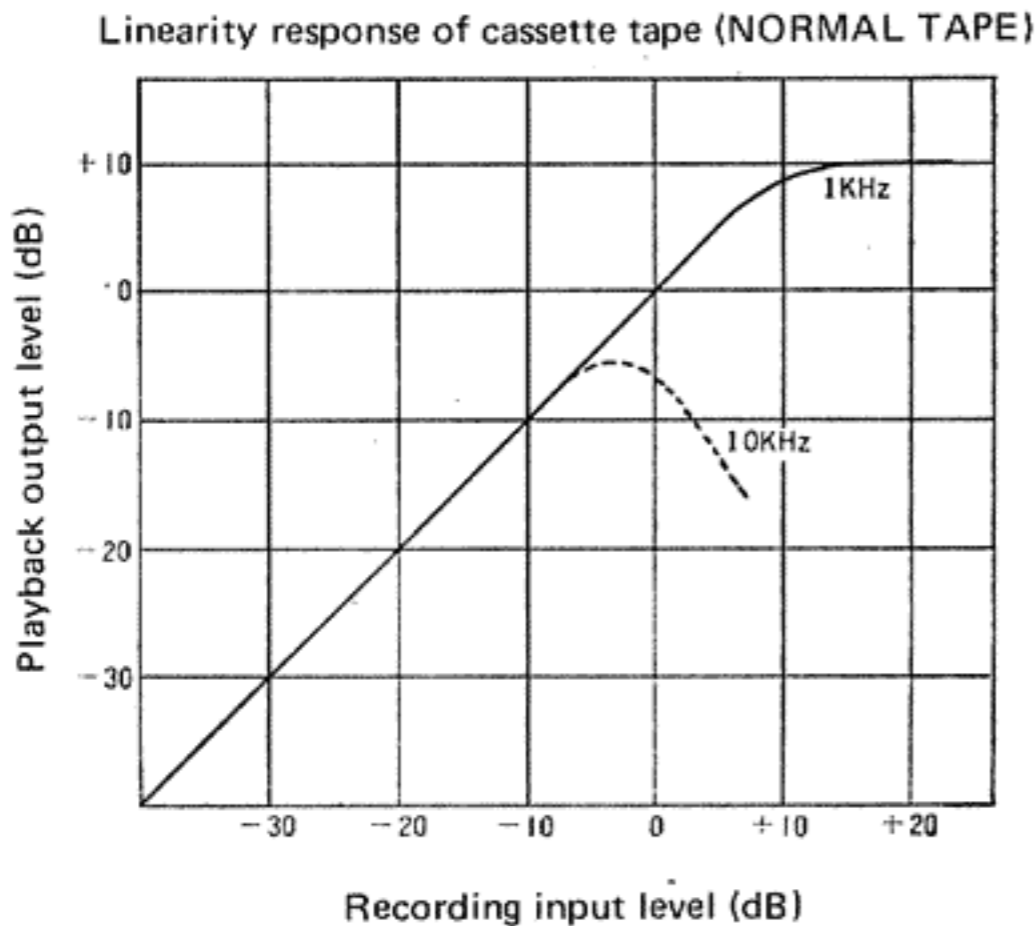

Fig. 8

* Dolby is a trademark of Dolby Laboratories Inc.

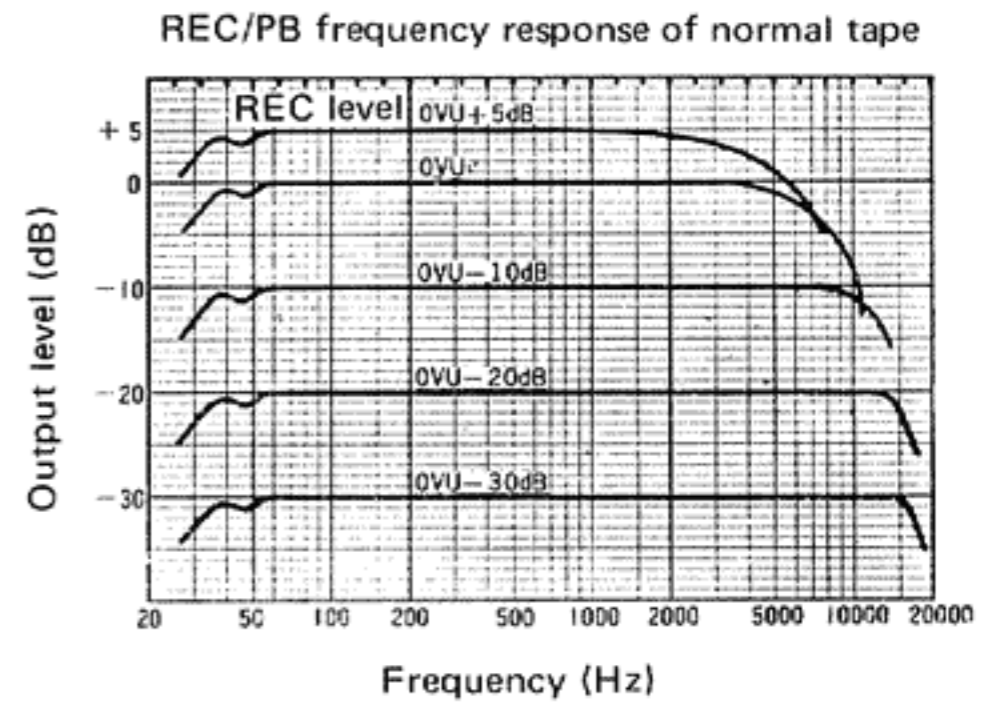

Fig. 9

2. Principles of Super ANRS

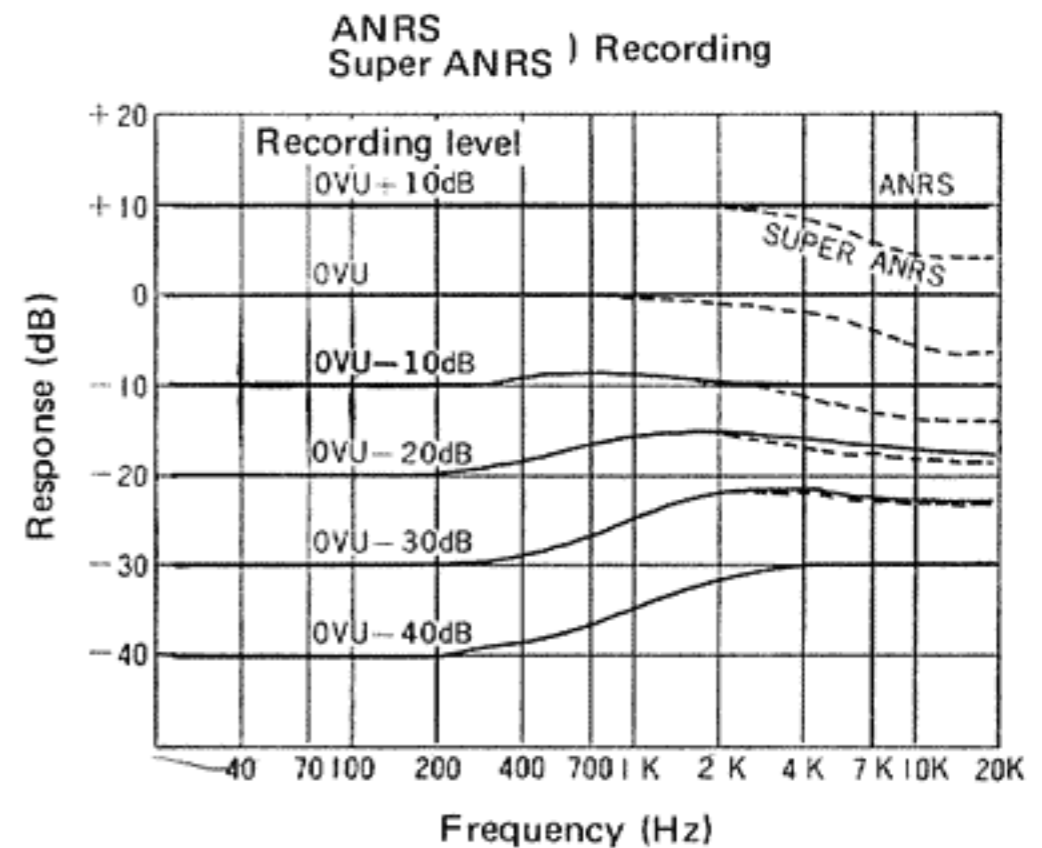

Fig. 10

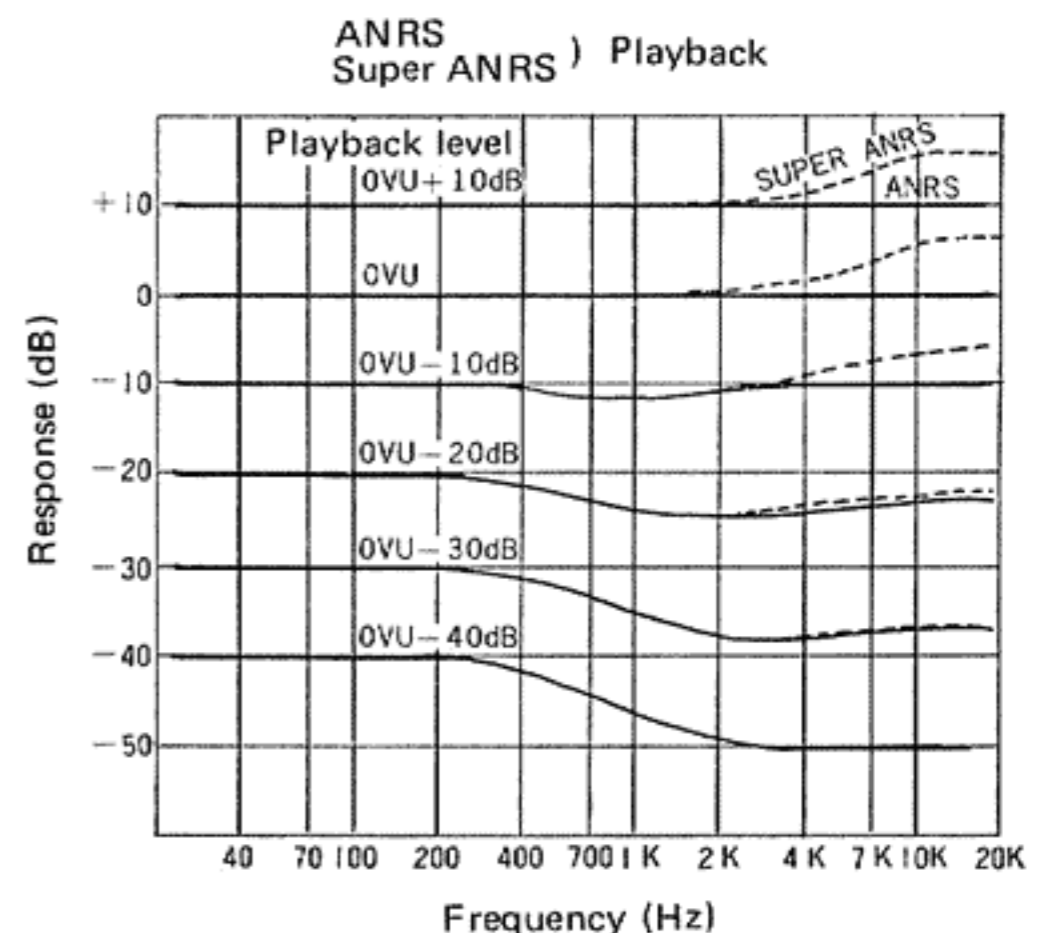

Fig. 11

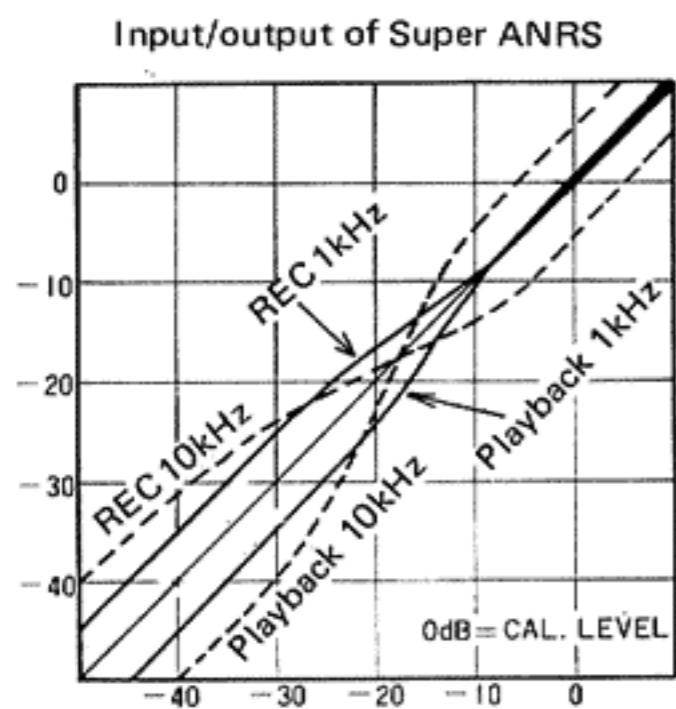

Fig. 12

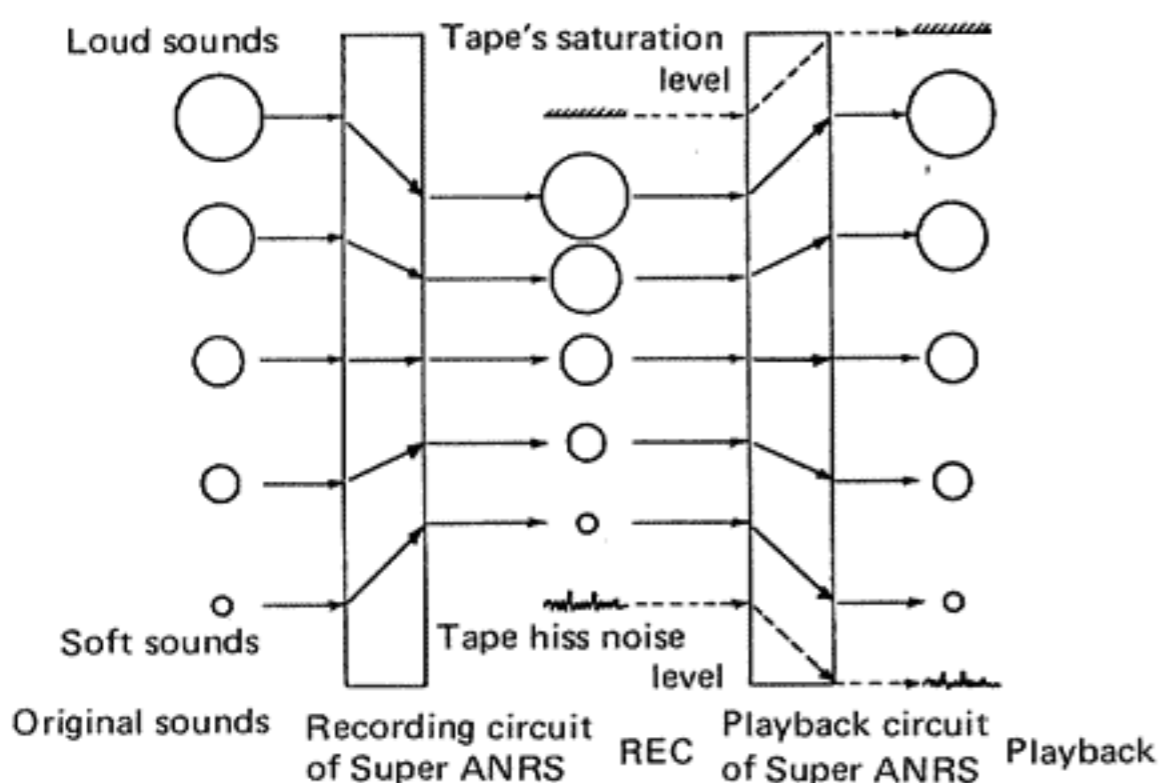

Fig. 13

In Figs. 10, and 11, the solid curves are for ANRS and the dotted curves are for Super ANRS. As you can see from Fig. 10, ANRS records high frequency signals at the same level as that at which they are input when the level is high and boosts the level when the signals are weak. When Super ANRS is added to this, Super ANRS reduces the level of high frequency signals at high levels. The characteristics in playback, as seen in Fig. 11, are completely complementary so that the original sound is faithfully reproduced.

Fig. 12 shows the input/output characteristics of Super ANRS. It works in the same way as ANRS for low level sounds, eliminating tape hiss; for high level signals, it works as a dynamic range expander.

Fig. 13 is an illustration of this principle. The sizes of the circles indicate the level of the sound; big circles for loud sounds, small circles for soft sounds. Super ANRS reduces higher level sounds and boosts lower level sounds in recording. These processed sounds are recorded on tape. In this way, loud sounds which would have exceeded the tape's saturation level and soft sounds which would have been obscured by tape hiss can be recorded. In playback, Super ANRS returns all recorded signals to their original levels; tape hiss is reduced to an inaudible level and the effective saturation level of the tape is raised, allowing a wider dynamic range.

3. Effects of Super ANRS

1) Noise Reduction

High frequency tape hiss noise is eliminated without affecting the original music signal, as with ANRS, improving the S/N ratio by 5dB at 1kHz and 10dB at 5kHz and more.

2) Improvement of linearity at high frequencies

Linearity at high frequencies is improved by 6dB at 10kHz for 0VU recording and 12dB at 10kHz for +5VU recording (Normal tape) as shown in Fig. 15.

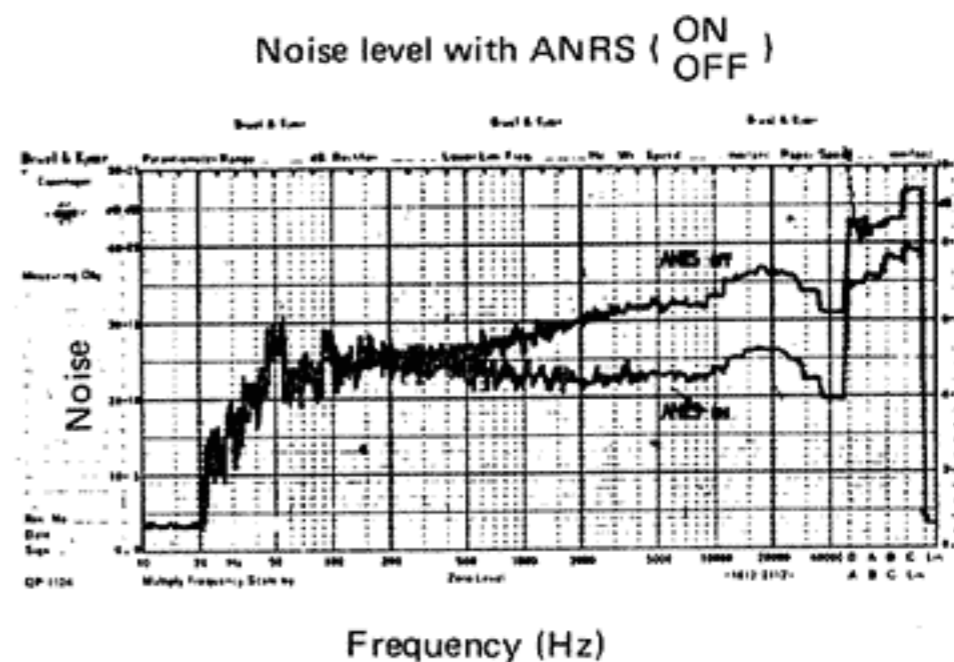

Fig. 14

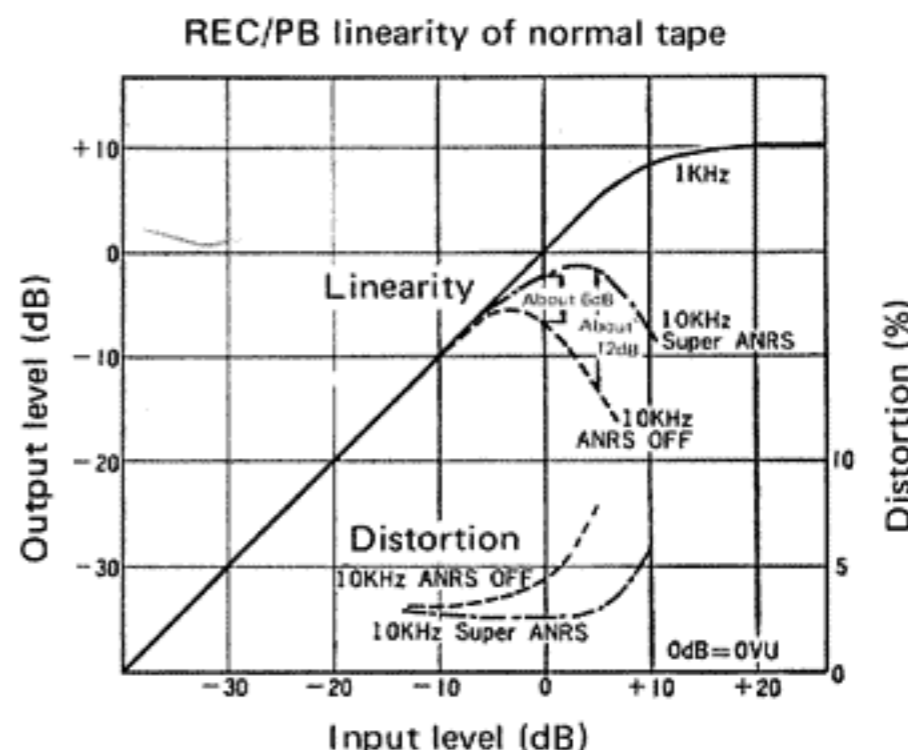

Fig. 15

These can be seen from the frequency response characteristics shown in Fig. 16-1 and 16-2.

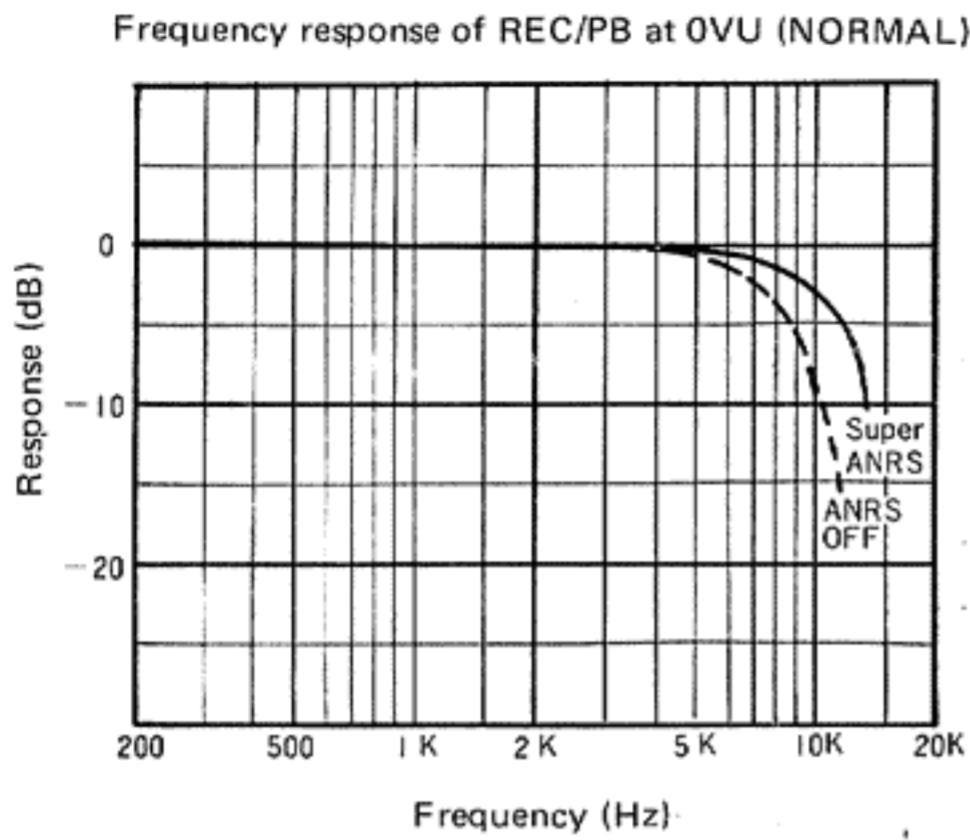

Fig. 16-1

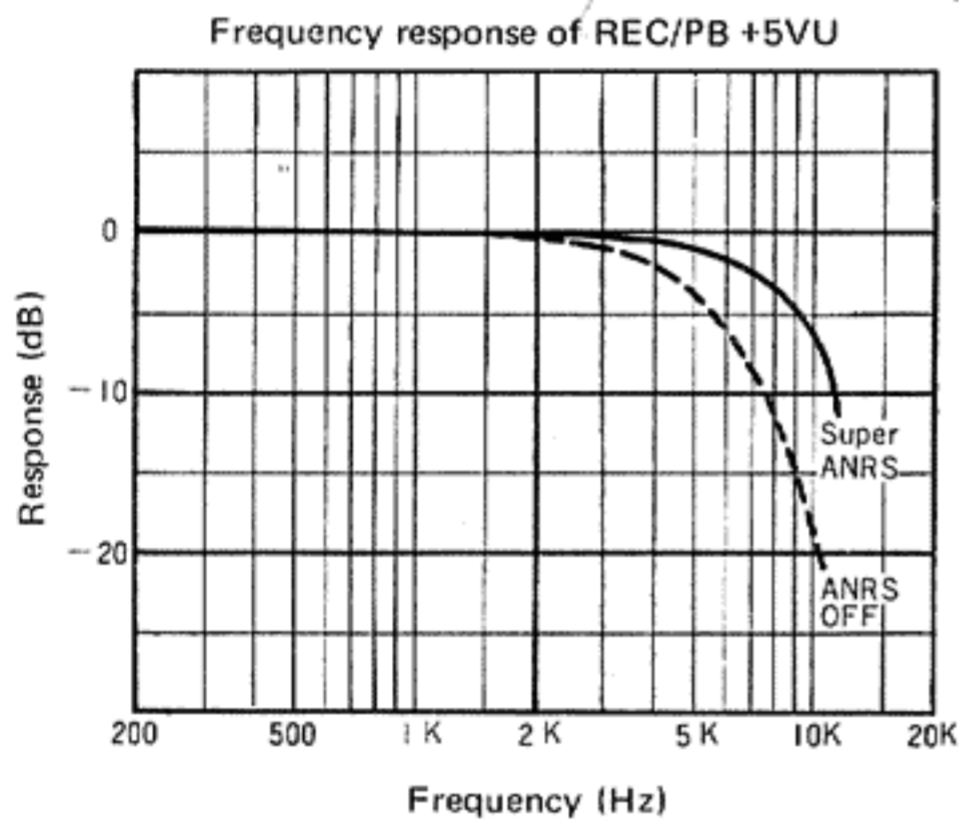

Fig. 16-2

4. Circuit Description

Basically, the Super ANRS circuit consists of the variable impedance circuit of ANRS and an additional high-cut filter element formed by R341, R518 and C510. When the input signal level is low (when R and C take increased values), the circuit characteristics are exactly the same as for ANRS. As the input level rises (with decreasing R and C values), the high-cut filter circuit begins to operate, giving the characteristics shown in Fig. 17.

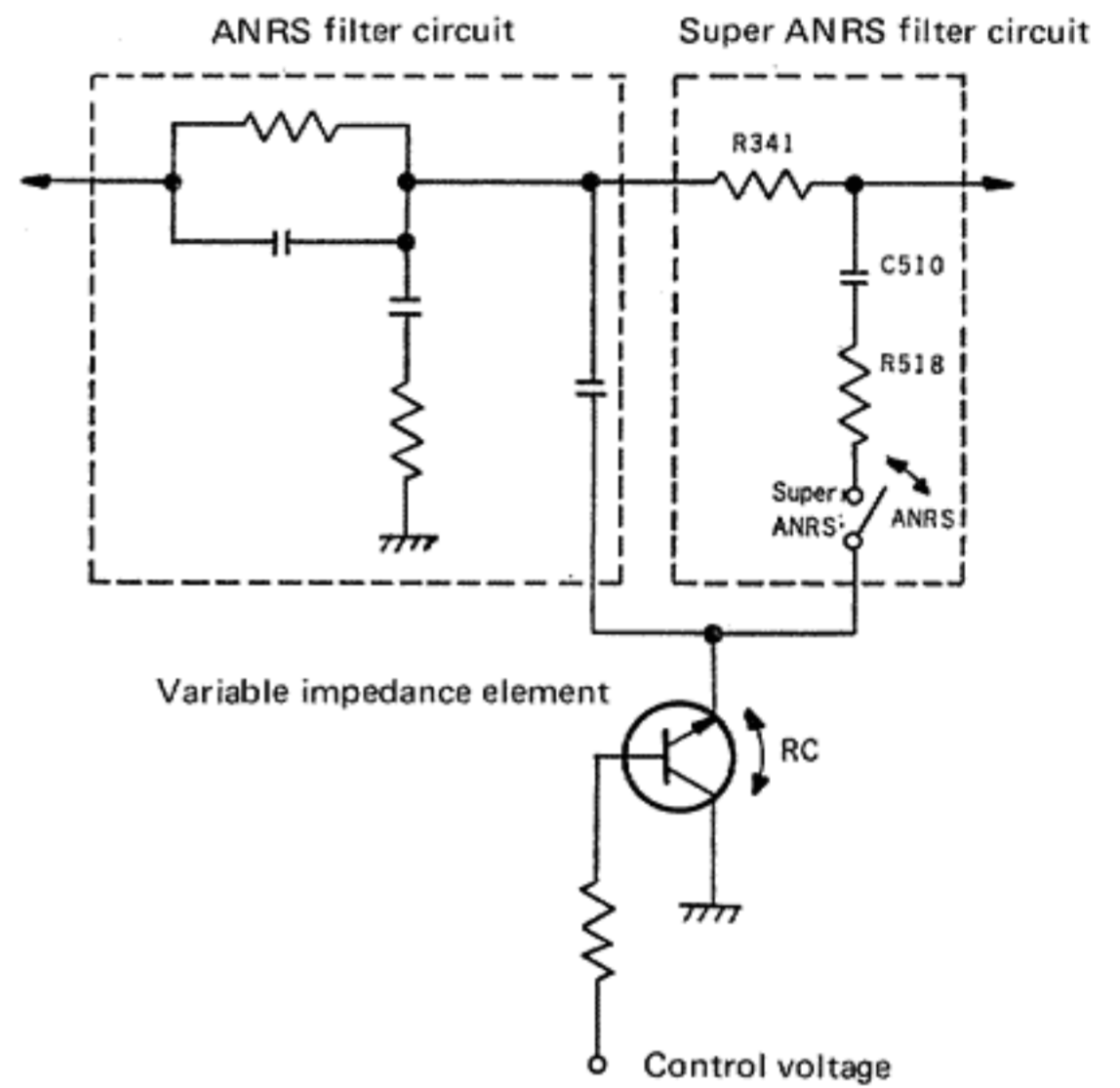

Fig. 17

Main Parts Removing & Replacement

This cassette deck which features a compact design and performance uses miniature-sized parts which are closely arranged. Use special care when servicing it.

Enclosure Assembly

Parts Name	Procedure	Ref. No.	Remarks
Bottom cover	<ol style="list-style-type: none"> 1. Remove the battery case, and then can be removed battery. (6 cells) 2. Remove 6 screws fastening the bottom cover. 3. Pull out 2 wire tips for the battery. 	[18] ①	In battery case is fixed 1 screw (3φ8mm) Orange, black wires
Control knobs	Pull out to front or upper side.		PB level control knob Tone control knob REC level control knobs (left and right) REC volume control knob
Top panel	<ol style="list-style-type: none"> 1. Press [EJECT] button, and the cassette cover will swing open, then remove 1 screw. 2. Remove 3 screws fastening the top panel. 3. Remove 4 tapping screws fastening the top panel. 4. Pull out 2 wire tips to speaker, then can be removed the top panel. 	[19] ② [21] ③ [21] ④	Black screw 2φ 4mm Black screws 3φ 6mm (front side of top panel) Black screws 3φ 3mm (front side of top panel)
Front panel	<ol style="list-style-type: none"> 1. Remove 5 tapping screws. 2. Remove 2 screws (left side). 3. Pull out the front panel to front side. 	[22,25,26] ⑤ [24] ⑤	Upper(1 pc.), under(1 pc.) and right(3 pcs.) sides, 3φ 6mm

Electric Parts

Parts Name	Procedure	Ref. No.	Remarks
Main amp circuit board	<ol style="list-style-type: none"> 1. Remove 4 screws fastening main amp circuit board. 2. Remove 2 screws fixing the bracket (heat sink plate) of transistors, and then remove shield board. 	[21] ⑥ [24] ⑦	Violet screws
ANRS circuit board	Remove 4 screws fastening ANRS circuit board, and then remove shield board.	[21] ⑧	Violet screws
Switch circuit board	<ol style="list-style-type: none"> 1. Remove 2 screws fastening SW circuit board. 2. Pull out 4 blind felts of switch shaft. 3. Remove 4 screws fastening the switches. 4. Remove 2 nuts and washers fastening variable resistors. 5. Pull out switch circuit board to back side. 	[23] ⑨ [23] ⑩ [23] ⑪	PB level control VR, Tone control VR
Power transformer	Remove 2 screws and washers (as same nuts) fastening power transformer.	[20] ⑫	

Mechanical Parts

Parts Name	Procedure	Ref. No.	Remarks
Mecha ass'y	<ol style="list-style-type: none"> 1. Remove ANRS circuit board. 2. Remove muting bracket. 3. Remove 3 screws fastening circuit board. (upper and under side of mecha ass'y) 	[27] (13) [27] (14)	
Motor ass'y	<ol style="list-style-type: none"> 1. Disconnect 2 wires to motor circuit board. 2. Remove capstan belt. 3. Remove 2 screws fastening bracket of motor circuit board. 4. Remove 3 screws (as same washers and rubber bushings) fastening motor. 	[27] (15) [28] (16)	Red, black wires Don't soil belt
Pinch roller arm ass'y	<ol style="list-style-type: none"> 1. Remove E ring pinch roller arm ass'y. 2. Remove pinch roller arm spring. (for pressure adjustment) 	[27] (17)	
Take-up reel (right side)	<ol style="list-style-type: none"> 1. Remove E ring holding take-up reel. 2. Remove take-up reel from shaft. 	[27] (18)	
Supply reel (left side)	<ol style="list-style-type: none"> 1. Remove E ring holding supply reel. 2. Remove supply reel from shaft. 	[27] (19)	
Flywheel	<ol style="list-style-type: none"> 1. Remove capstan belt. 2. Remove 2 screws fixing flywheel holder. 3. Remove E ring holding take-up idler arm. 4. Pull out flywheel. 	[28] (20) [28] (21)	Don't soil belt.

[Note] Almost all the mechanical parts can be adjusted and replaced when only the ANRS circuit board is removed.

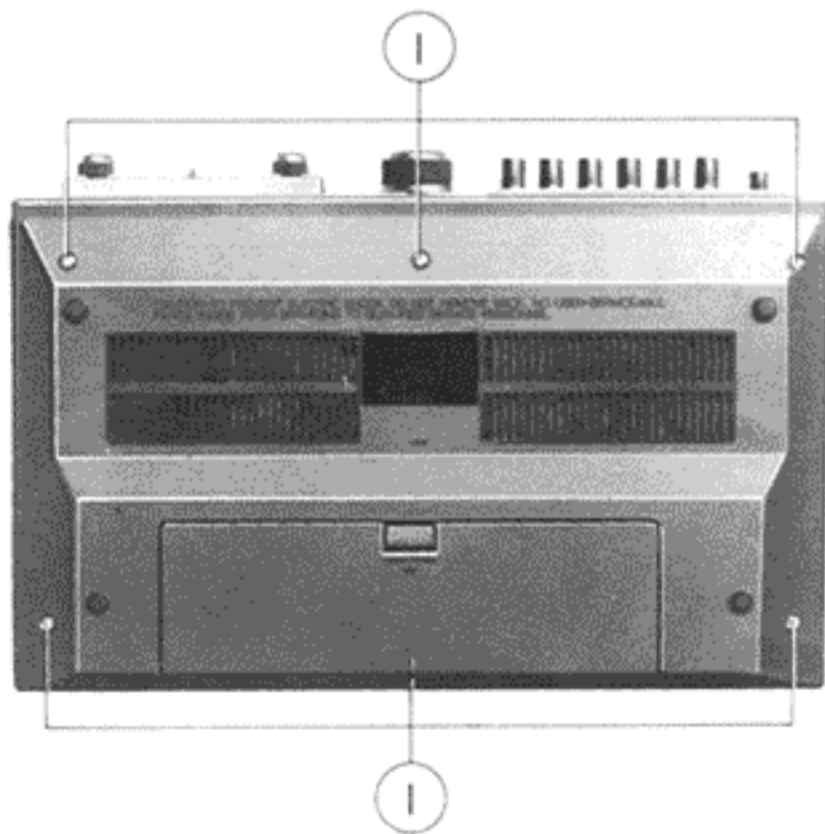

Fig. 18

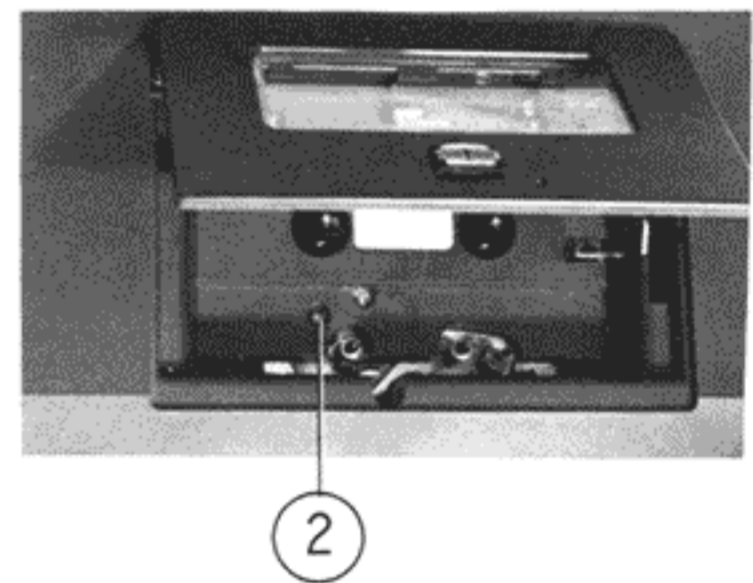

Fig. 19

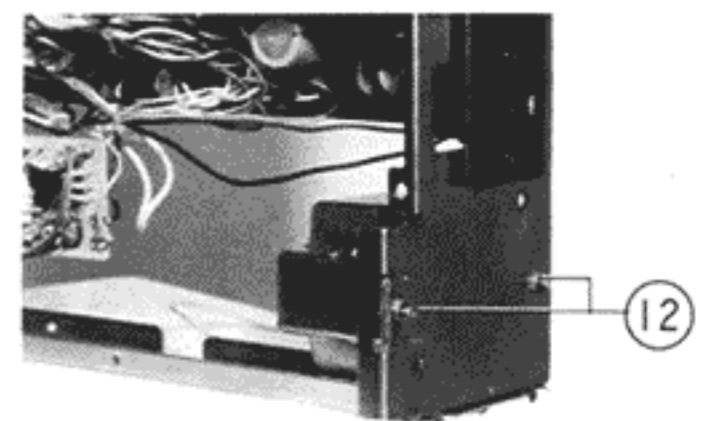

Fig. 20

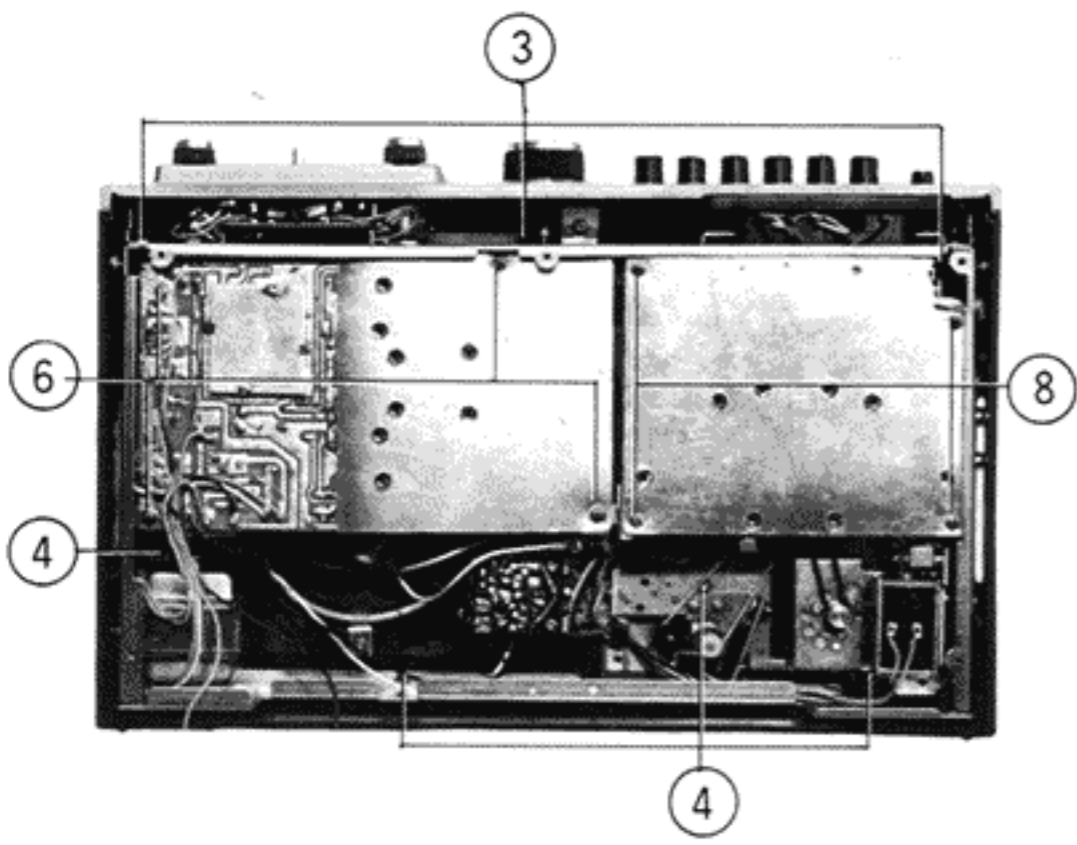

Fig. 21

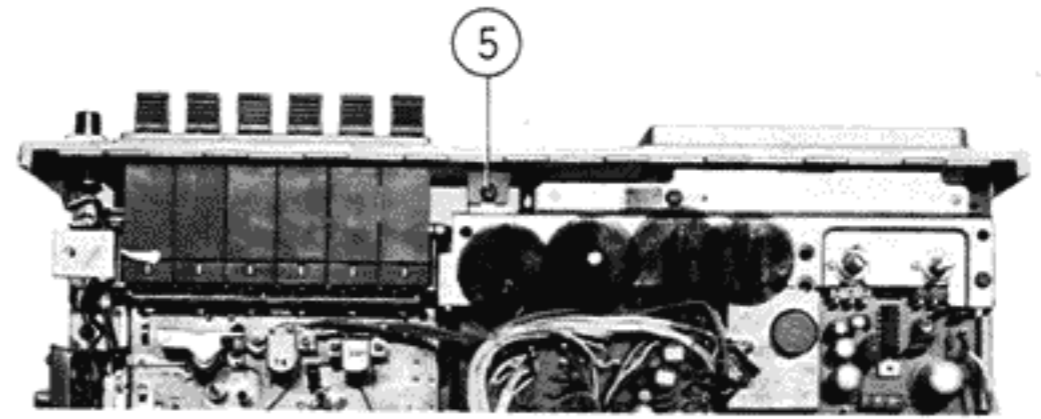

Fig. 25

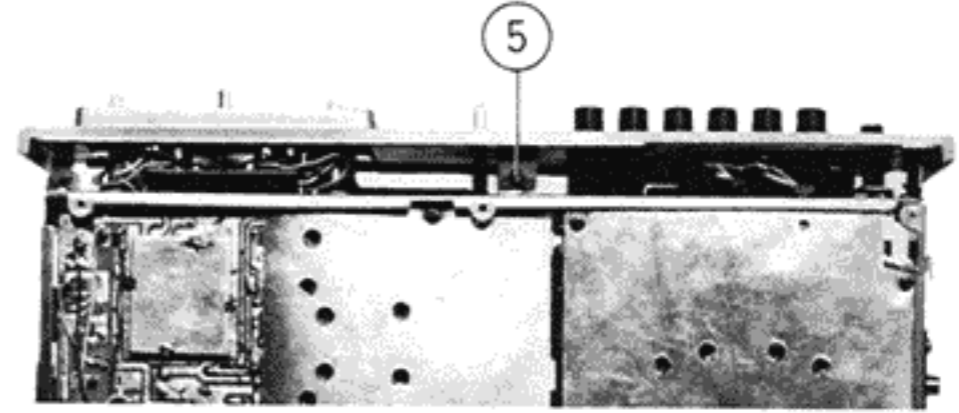

Fig. 26

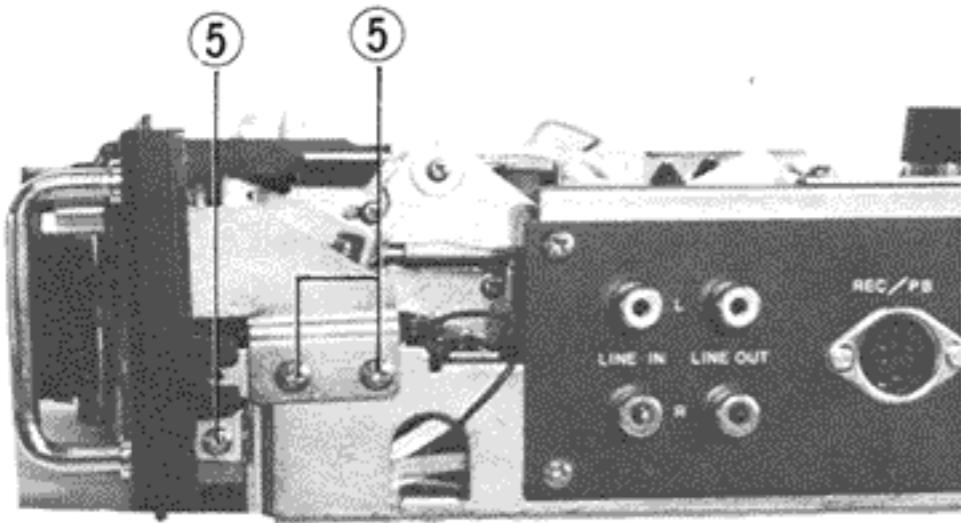

Fig. 22

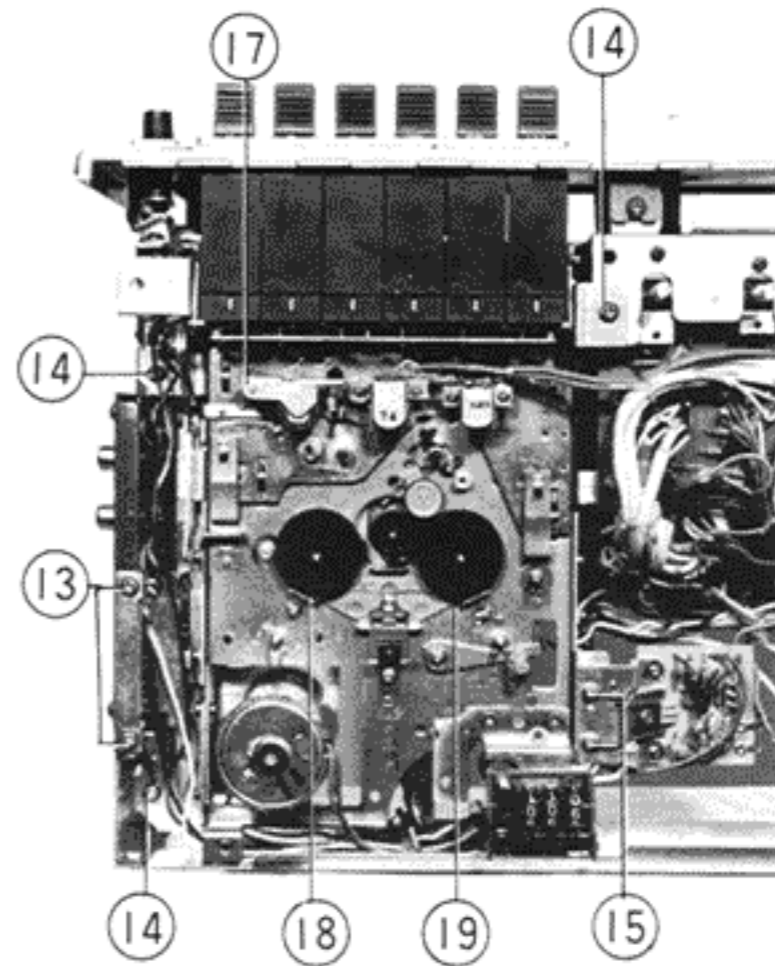

Fig. 27

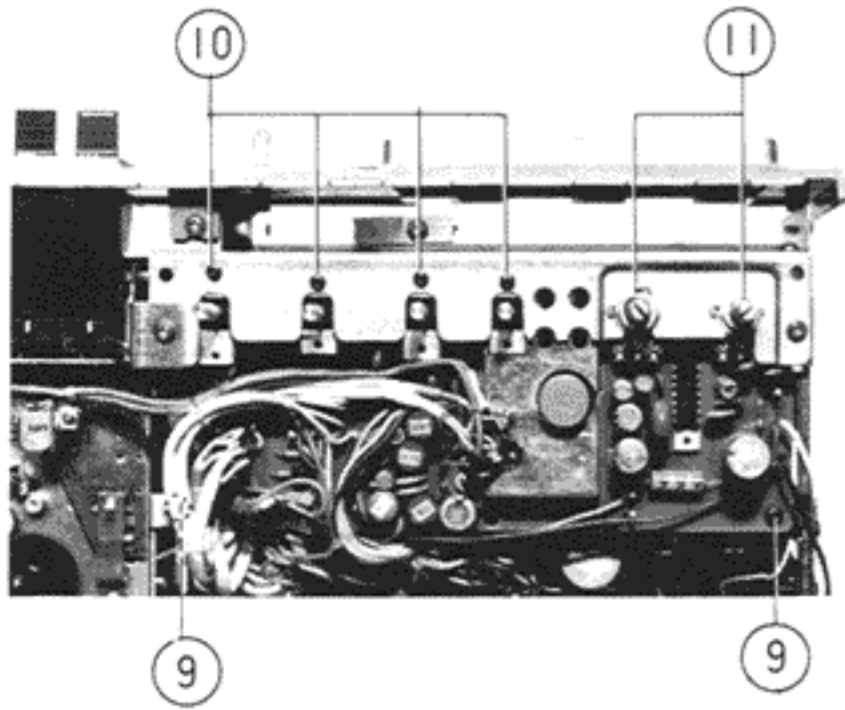

Fig. 23

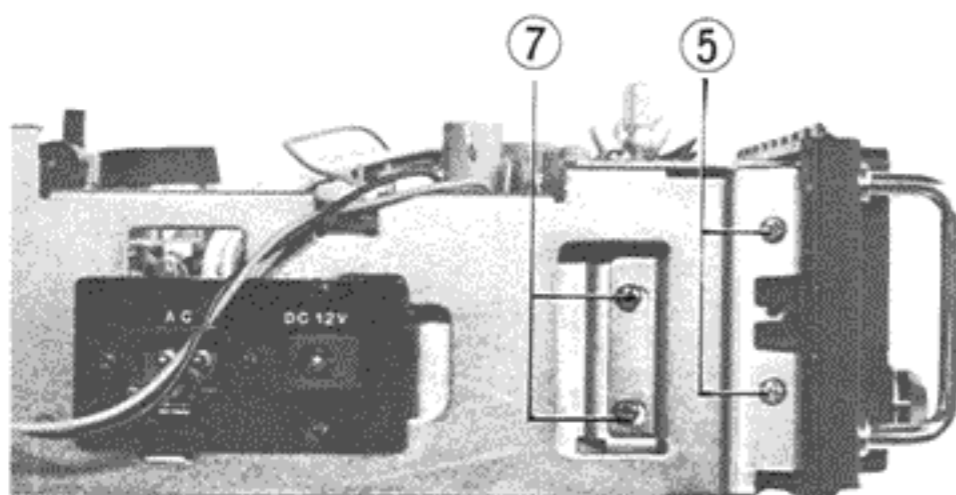

Fig. 24

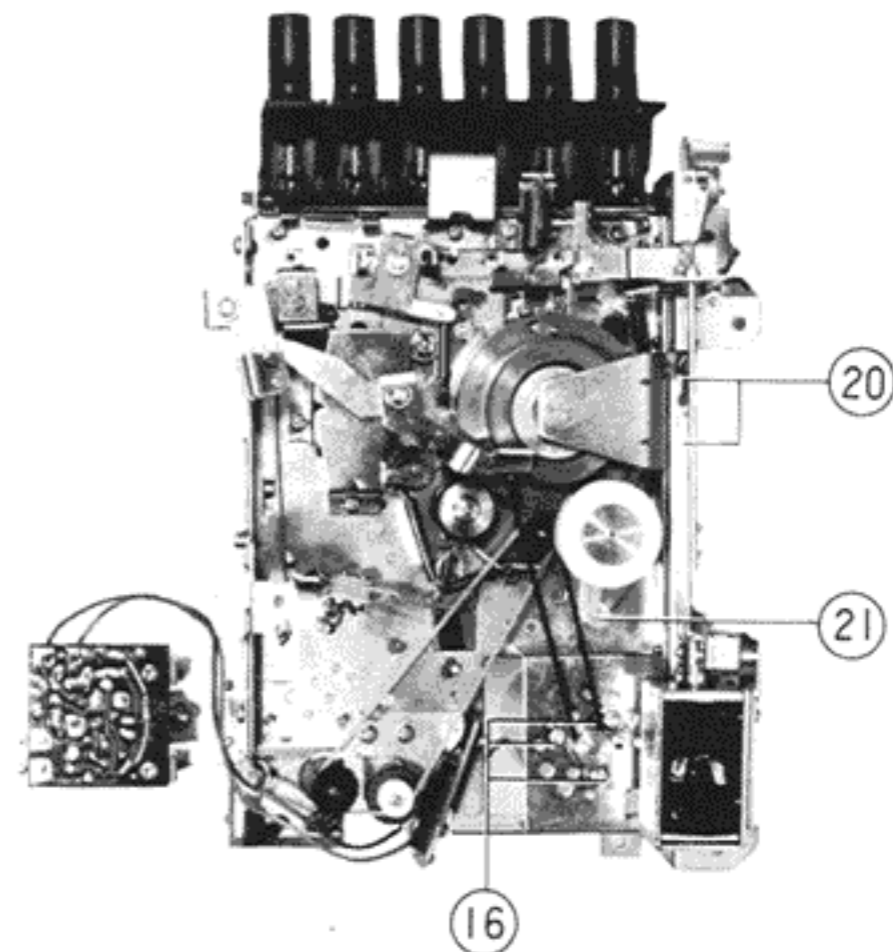

Fig. 28

Main Adjustments

Electrical Adjustments

Equipment and measuring instruments used for adjustment.

1. Audio-frequency oscillator
2. Attenuator
3. V.T.V.M (measuring AC in millivolts)
4. Test tapes (VTT-664 1kHz 16mM)
5. Blank tapes (QP-12 C521V standard tape), TP-18 CrO₂ C401R (CrO₂ tape) or equivalent.
6. Resistors 100Ω (for measurement of the bias current)
600Ω (for attenuator matching)

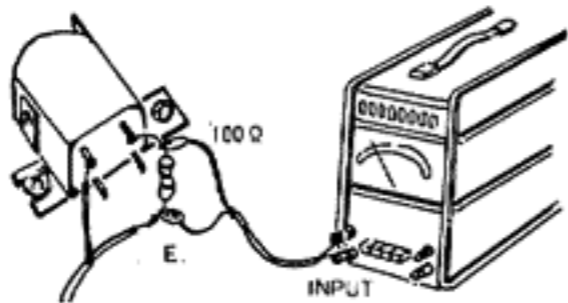
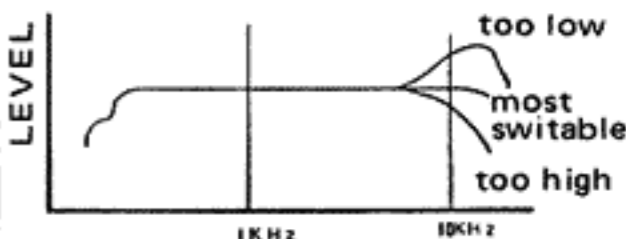
No.	Item	Procedure	Part	Rating	Remarks
1.	Level meter deflection	<ol style="list-style-type: none"> 1. Set the deck in the record mode. 2. Input 1kHz signals from MIC or LINE IN jacks (with a level of -60dB approx. for MIC input or -10dBs approx. for LINE IN input.) Adjust the recording volume controls so that the voltage across LINE OUT is -8dBs. 3. Adjust two semi-fixed variable resistors R134(L-ch) R234(R-ch) so that the level meters indicate zero VU. 	R134	VU meter reading: 0	The angle of meter deflection has been factory-adjusted, but should be adjusted when parts are replaced.
2.	Reproduction level	Adjust R115 and R215 to obtain zero VU meter reading using reference tape VTT-664 1kHz 16mM (old ref. no. TMT-6009). Set equalizer switch in "NORMAL" position and turn off ANRS switch when adjusting reproduction level.	R115 R215	VU meter reading: 0	<ol style="list-style-type: none"> 1. Adjust reproduction level when heads are replaced. 2. Make this adjustment after making sure level meter deflection angle is correct.
3.	Recording bias	<ol style="list-style-type: none"> 1. Set the deck in the record 2. Connect a 100Ω resistor into the ground side (at recording mode) wiring of the head. 3. Connect the AC V.T.V.M across the resistor, and measure its voltage. <div style="text-align: center;">  <p>Fig. 29</p> </div> <p>If no measuring apparatus is available, check in the following way. Music sound is not sonorous in the high range on playback: bias current is too high. Music sound is also sonorous in the high range on playback but distorted: bias current is too low.</p>	Standard tape: R555,557 CrO ₂ tape: R556,558 (BIAS ADJ)	Approx. 37mV Approx. 47mV	<ol style="list-style-type: none"> 1. Adjust recording bias current when heads are replaced. 2. Use a measuring apparatus of excellent frequency characteristic. 3. Be sure to connect resistor to head terminal. It is recommended to check the following after adjustment. (ANRS → OFF) (Set EQ and BIAS switches according to type of tape used.) <p>Obtain zero VU meter reading at 1kHz, attenuate signal by 20dB, record and play at 1 and 10kHz. Then adjust bias current so that measuring apparatus shows the same output at 1 and 10kHz.</p> <div style="text-align: center;">  <p>Fig. 30</p> </div> <p>Attend the bias current to change with distortion affection.</p>

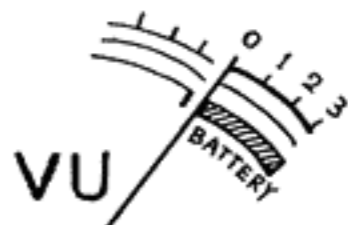
No.	Item	Procedure	Part	Rating	Remarks
4.	Recording level	<p>A: Adjustment for normal tape (Use JVC reference tape.)</p> <ol style="list-style-type: none"> 1. Set the deck in the record mode. 2. Input 1kHz signals from MIC or AUX IN jacks and make recording in such a way that the level meters indicate zero VU. 3. Adjust R142 and R242 till reproduction level is reduced to zero when the reference tape is played. <p>B: Adjustment for CrO₂ tape (Use JVC reference tape.)</p> <ol style="list-style-type: none"> 1. Set the deck in the record mode. 2. Input 1kHz signals from MIC or AUX IN jacks and make recording in such a way that the level meters indicate zero VU. 3. Adjust R138, and R238 till reproduction level is reduced to zero when the reference tape is played. 	<p>R142,242 (REC LEVEL NOR)</p> <p>R138,238 (REC LEVEL CHROM)</p>		<ol style="list-style-type: none"> 1. This adjustment is necessary when heads are replaced. 2. Make this adjustment after adjusting level meter deflection angle, reproduction level and recording bias current. 3. Set EQ and BIAS switches according to type of tape used. 4. Turn off ANRS switch.
5.	ANRS circuit	<ol style="list-style-type: none"> 1. Disconnect power connection receptacle of bias oscillator so that oscillator does not operate. 2. Set the deck in the record mode. 3. Input 1kHz -10dBs signals from LINE IN jacks adjust the recording volume controls so that the voltage across LINE OUT is -5dBs. 4. Turn R335 and R435 (CONT GAIN) and R340 and R440 (DC BIAS) in the direction opposite to the marking. 5. Adjust R324 and R424 so that level does not change when ANRS is turned on and off, and turn on ANRS. 6. Input 1kHz, -50dBs signals from LINE IN. Adjust R340 and R440 so that voltage across LINE OUT is -39.5dBs. 7. Input 5kHz -30dBs signals from LINE IN. Adjust R335 and R435 so that voltage across LINE OUT is -21.5dBs. 8. Repeat steps (5) through (7). 9. Turn ANRS switch in "Super" position when input 10kHz -10dBs signals from LINE IN. Check output levels are -11dBs ±2dB. 10. Connect receptacle of bias oscillator disconnected in step (1). 11. Play reference tape VTT-664 and adjust R302 and R402 so that level does not change when ANRS is turned on and off. 	<p>R324,424 (REC GAIN)</p> <p>R340,440 (DC BIAS)</p> <p>R335,435 (CONT GAIN)</p> <p>R302,402 (PB GAIN)</p>		
6.	Battery	<ol style="list-style-type: none"> 1. Apply exactly 6V to battery contacts and switch machine to play or fast forward. 2. Turn down battery check switch in "CHECK" position and adjust so that meter pointer deflects to the other end of green area. 			<p>Do not mistake one polarity for the other.</p>  <p>Fig. 31</p>

Block Diagram

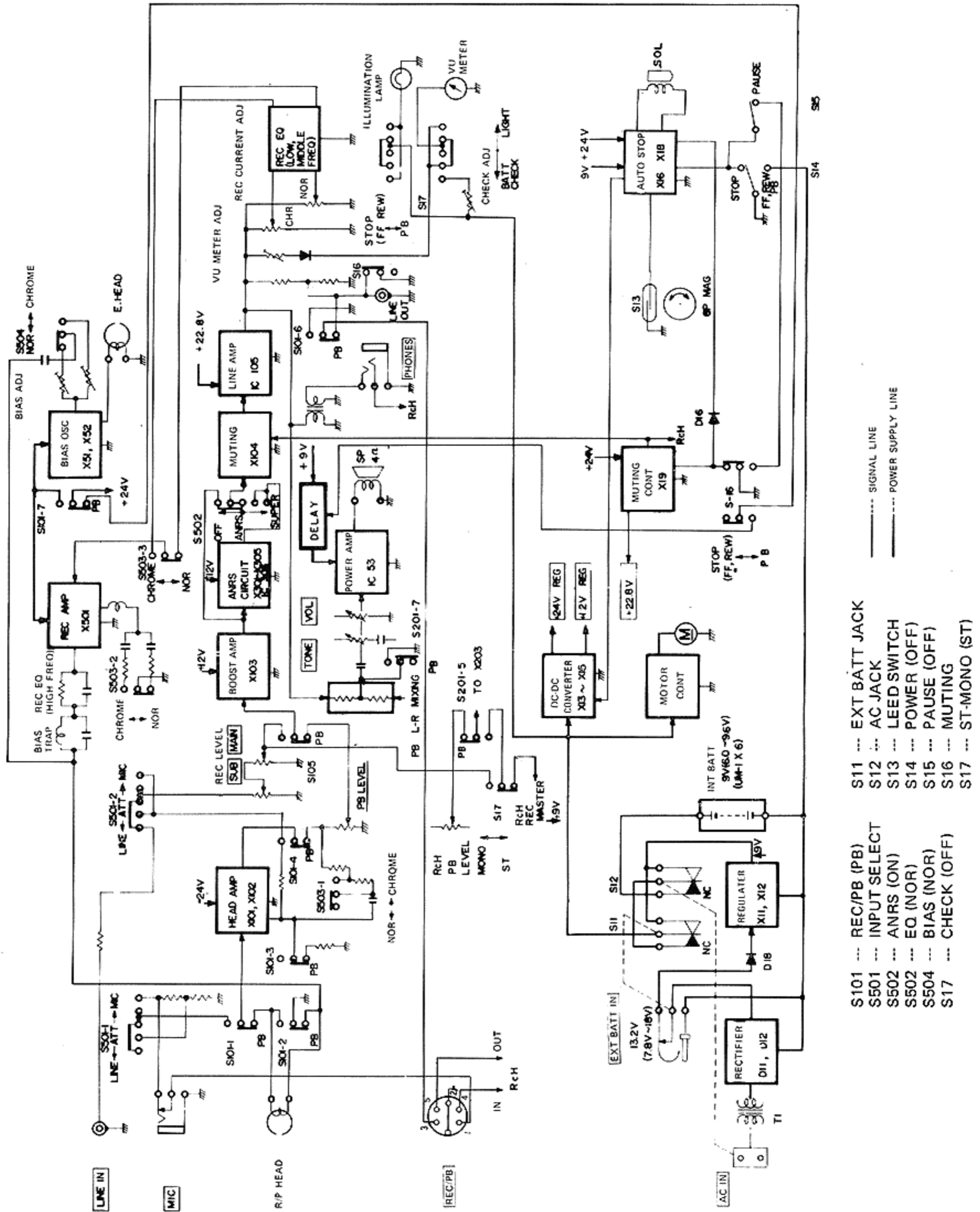

Fig. 32

Variable Resistor

R115,215	P.B Level Adj.	50kΩ
R134,234	Meter Adj.	1kΩ
R138,238	REC Level Adj. (chrome)	20kΩ
R142,242	" (normal)	20kΩ
R302,402	ANRS P.B Gain Adj.	10kΩ
R324,424	ANRS REC Gain Adj.	10kΩ
R335,435	ANRS Control Gain Adj.	20kΩ
R340,440	ANRS DC Bias Adj.	100kΩ
R556,558	Bias Current Adj. (chrome)	100kΩ
R555,557	" (normal)	200kΩ

Switch

S101-1~7 (201)	REC-PB SW at "PB" mode
S301-1~4 (401)	
S501-1~2 (601)	INPUT SW at "LINE" mode
S502 (602)	ANRS SW at "OFF"
S503-1~3 (603)	EQ SW at "NORMAL"
S504 (604)	BIAS SW at "NORMAL"
S17-1~2	CHECK SW at "OFF"
S11	EXT. BATT JACK
S12	AC JACK
S13	REED SW
S14	POWER SW at "OFF"
S15	PAUSE SW at "OFF"
S16	MUTING SW
S17	REC MODE select SW at "Stereo" mode

Diode

D101,201	1S188AM
D102,202	1S188AM
X103,203	MA-150
D301,401	1S188FM
D392,402	1S188EM
D31	MA26W
D11-1,-2	T30154-001
D12-1,-2	or V06B
XD13	RD10E(1)
D14	MA150
D15	1S188AM
D16	MA150
D17,18	T30155-001 or V06B
D19	MA26W
ZD20	RD-22E(1)
D21	MA162
D22	MA161
D23	MA150
D24,25	MA150
D26	MA450
[SCR]	2SF656

Transistor & IC

X101,201	2SA721(TU)
X102,202	2SC1327(TU)
X103,203	2SC1327(TU)
X104,204	2SC828(RS)
IC105,205	TA7066P(B)
X301,401	2SC1327(TU)
X302,402	2SC933FP
X303,403	2SA721(TU)
X304,404	2SC1327(TU)
X305,405	2SC828(R)
IC306,406	TA7066P(BC)
X501,601	2SC828A(R)
X51,52	2SC828A(RS)
IC53	LA4102
X11	2SC828(RS)
X12	2SD313(DE)
X13	2SC828(R)
X14	2SC1384(R)
X15	2SC13S4(R)
X16	2SC828(RS)
X17	2SC828A(RS)
X18	2SA564A(RS)
X19	2SA564A(RS)
X20	2SC1383(RS)
X21	2SC828(RS)

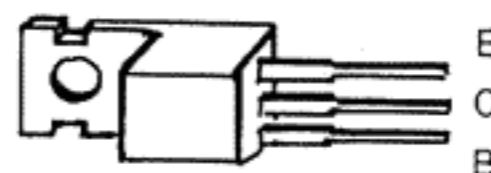

2SD313

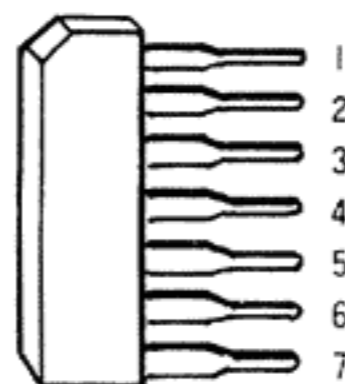

TA7066P

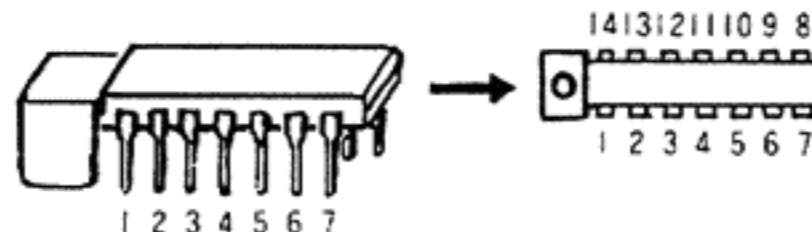

LA4102

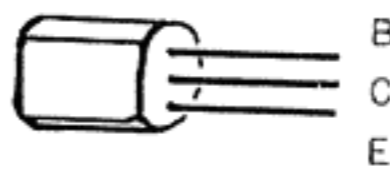

2SA721
2SC1327
2SC828
2SC828A
2SA564A
2SC933FP

Fig. 33

Circuit Board Parts

Main Amp Circuit Board

Red print is shown the voltage (V) of playback mode.
 () voltage; at recording mode.

When you measure the voltage by tester, we recommend you to use 20kΩ/V or more impedance tester.

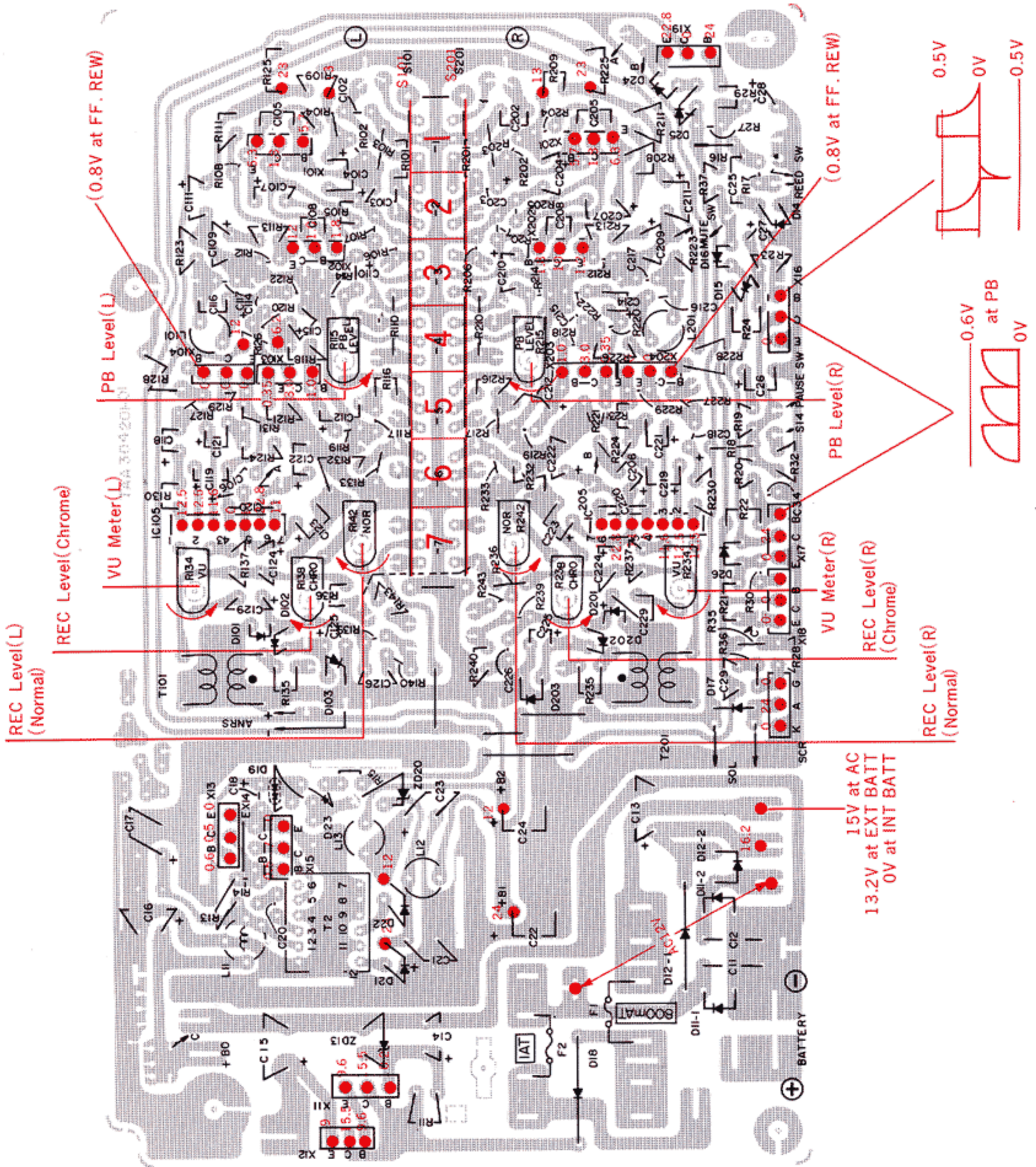

Fig. 34

Main Amp Circuit Board Parts List

Ref. No.	Parts No.	Parts Name	Remarks	Q'ty
	*TAA304201-02	Circuit Board		1
	QMG1321-001	Fuse Holder		2
	*QMF51A2-R80	Fuse	0.8A	1
	" -1R0	"	"	1
	TAZ000445-06	Fuse Seal	800mAT	1
	" -01	"	1.0AT	1
	LPSP2608Z	Screw	for fuse holder	2
(REC/PB AMP)				
S101,201	T31519-001	Slide Switch		1
R102,202	QRZ0019-104	C. Resistor (Low noise)	100kΩ ¼W	2
R103,203	" -823	" (")	82kΩ "	2
R105,205,136,236	QRD143K-563	C. Resistor	56kΩ "	4
R109,209,114,214	" -104	"	100kΩ "	4
R119,219	" -823	"	82kΩ "	2
R104,204,108,208	" -274	"	270kΩ "	4
R106,206	" -221	"	220Ω "	2
R107,207	" -391	"	390Ω "	2
R110,210,128,228, 129,229,139,239, 143,243	" -473	"	47kΩ "	10
R111,211	" -103	"	10kΩ "	2
R112,212,116,216	" -102	"	1kΩ "	4
R113,213	" -121	"	120Ω "	2
R115,215	QVP8A0B-054	V. Resistor	50kΩ "	2
R117,217	QRD143K-224	C. Resistor	220kΩ "	2
R118,218	" -394	"	390kΩ "	2
R120,220	" -472	"	4.7kΩ "	2
R121,221	" -561	"	560Ω "	2
R122,222,124,224	" -123	"	12kΩ "	4
R123,223	" -223	"	22kΩ "	2
R125,225	" -821	"	820Ω "	2
R126,226	" -822	"	8.2kΩ "	2
R127,227	" -562	"	5.6kΩ "	2
R130,230	" -471	"	470Ω "	2
R131,231	" -181	"	180Ω "	2
R132,232	" -332	"	3.3kΩ "	2
R133,233	" -682	"	6.8kΩ "	2
R134,234	QVP8A0B-013	V. Resistor	1kΩ B	2
R135,235	QRD143K-2R7	C. Resistor	2.7Ω ¼W	2
R137,237	" -151	"	150Ω "	2
R138,238,142,242	QVP8A0B-024	V. Resistor	20kΩ B	4
R140,240	QRD143K-393	C. Resistor	39kΩ ¼W	2
C102,202	QCS11HK-331	Ceramic Capacitor	330PF	2
C103,203	QEE41EM-475	Tantal E. Capacitor	47μF 25V	2
C104,204	QEB41EM-476	LLC E. Capacitor	47μF "	2
C105,205	QCS11HK-471	Ceramic Capacitor	470PF	2
C106,206	QEB41HM-474M	E. Capacitor	10μF	2
C107,207	QEB41EM-336	LLC E. Capacitor	33μF 25V	2
C108,208	QCS11HK-470	Ceramic Capacitor	47PF	2
C109,209	QEW41AA-107	E. Capacitor	100PF 10V	2
C110,210	QEB41EM-105	LLC E. Capacitor	1μF 25V	2
C111,211	QEW41EA-476	E. Capacitor	47μF "	2
C112,212	QEB41EM-475	LLC E. Capacitor	4.7μF "	2
C114,214	QEW41CA-106	E. Capacitor	10μF "	2
C115,215	QEW41AA-476	"	47μF 10V	2
C116,216	QCS11HJ-820	Ceramic Capacitor	82PF	2
C117,217	QFM41HJ-272	Mylar Capacitor	0.0027μF 50V	2
C118,218,123,223, 124,224	QEW41EA-475	E. Capacitor	4.7μF 25V	6

Ref. No.	Parts No.	Parts Name	Remarks	Q'ty
C119,219	QEW41EA-336	E. Capacitor	33 μ F 25V	2
C120,220	QFM41HK-102	Mylar Capacitor	1000PF 50V	2
C121,221	QEW41EA-106	E. Capacitor	10 μ F 25V	2
C122,222	" -107	"	100 μ F "	2
C125,225	QEW41AA-336	"	33 μ F "	2
C126,226	QFM41HK-182	Mylar Capacitor	1800PF 50V	2
C129,229	QEW41EA-335	E. Capacitor	3.3 μ F 25V	2
L101,201	TAC000324-05	Inductor	33mH	2
T101,201	T44944-001	H.P. Trans		2
X101,201	2SA721 (TU)	Transistor		2
X102,202,103,203	2SC1327(TU)	"		4
X104,204	2SC828(RS)	"		2
IC105,205	TA7066P(B)	IC		2
D103,203	MA150	Diode		2
D101,102,201,202	1S188AM	"		4
(Power Supply)				
R11	QRD143K-272	C. Resistor	2.7k Ω 1/4W	1
C11,12	QCF12HP-103	"	0.01 μ F "	2
C13	QEW41EA-108	E. Capacitor	1000 μ F 25V	1
C14	QEW41CA-477	"	470 μ F 16V	1
C15	QEW41AA-338	"	3300 μ F 10V	1
X11	2SC828(RS)	Transistor		1
X12	2SD313(DE)	"		1
D11-1,-2,12-1,-2	T30155-001	Diode		4
D18	V06B	"		1
ZD13	RD10E(I)	Zener Diode		1
	TAR271478-01	Heat Sink		1
	SPKP3008S	Screw		1
	WBS3000	T. Lock Washer		1
(DC-DC Converter)				
R13	QRD143K-182	C. Resistor	1.8k Ω 1/4W	1
R14	" -220	"	22 Ω "	1
R15	" -102	"	1k Ω "	1
C16,18	QEW41AA-107	E. Capacitor	100 μ F 10V	2
C17	" -227	"	220 μ F "	1
C20	QFM41HJ-103	Mylar Capacitor	0.01 μ F 50V	1
C21	QEW41EA-476	E. Capacitor	47 μ F 25V	1
C22	" -477	"	470 μ F "	2
C23	QEW41CA-476	"	47 μ F "	1
C24	" -477	"	470 μ F "	1
L11	TAC000330-01	Inductor	330 μ F	1
L12	TAC000324-02	"	6.8mH	1
L13	" -04	"	5.6mH	1
X13	2SC828(R)	Transistor		1
X14,15	2SC1384(R)	"		2
D19	MA26W	Varistor Diode		1
ZD20	RD22E(I)	Zener Diode		1
D21	MA162	Diode		1
D22	MA161	"		1
D23	MA150	"		1
T2	TAZ271302-01	Converter Trans		1
	TAS271405-01	Converter Case (A)		1
	TAS271406-01	" (B)		1
(Auto Stop & Mute)				
R16,18	QRD143K-104	C. Resistor	100k Ω 1/4W	2
R17	" -333	"	33k Ω "	1
R19	" -100	"	10 Ω "	1
R20,30	" -472	"	4.7k Ω "	2

Ref. No.	Parts No.	Parts Name	Remarks	Q'ty
R21	QRD143K-103	C. Resistor	10k Ω ¼W	1
R22	" -124	"	120k Ω "	1
R23	" -823	"	82k Ω "	1
R24	" -223	"	22k Ω "	1
R27	" -153	"	1k Ω "	1
R28	" -102	"	15k Ω "	1
R29	" -183	"	18k Ω "	1
R30,37	" -472	"	4.7k Ω "	2
R32	" -122	"	1.2k Ω "	1
R35	" -102	"	1k Ω "	1
R36	" -182	"	1.8k Ω "	1
C25	QFM41HK-104	Mylar Capacitor	0.4 μ F 50V	1
C26	QEW41AA-227M	E. Capacitor	220 μ F 10V	1
C27	" -107	"	100 μ F "	1
C28	QEW41EM-336	LLC E. Capacitor	33 μ F 25V	1
C29	QFM41HK-333	Mylar Capacitor	0.033 μ F 50V	1
C34	OCF11HP-103	Ceramic Capacitor	0.01 μ F	1
X16	2SC828(RS)	Transistor		1
X17	2SC828A(RS)	"		1
X18,19	2SA564A(RS)	"		2
D14,16,24,26	MA150	Diode		4
D15	1S188AM	"		1
D17	T30155-001 or V06B	"	(10D-1)	1
	2SF656	S.C.R		1
	E40516-001	Tab		10
	A43596-001	"		2

ANRS Circuit Board

Red print is shown the voltage (V) of playback mode.

() voltage; at recording mode.

When you measure the voltage by tester, we recommend you to use 20k Ω /V or more impedance tester.

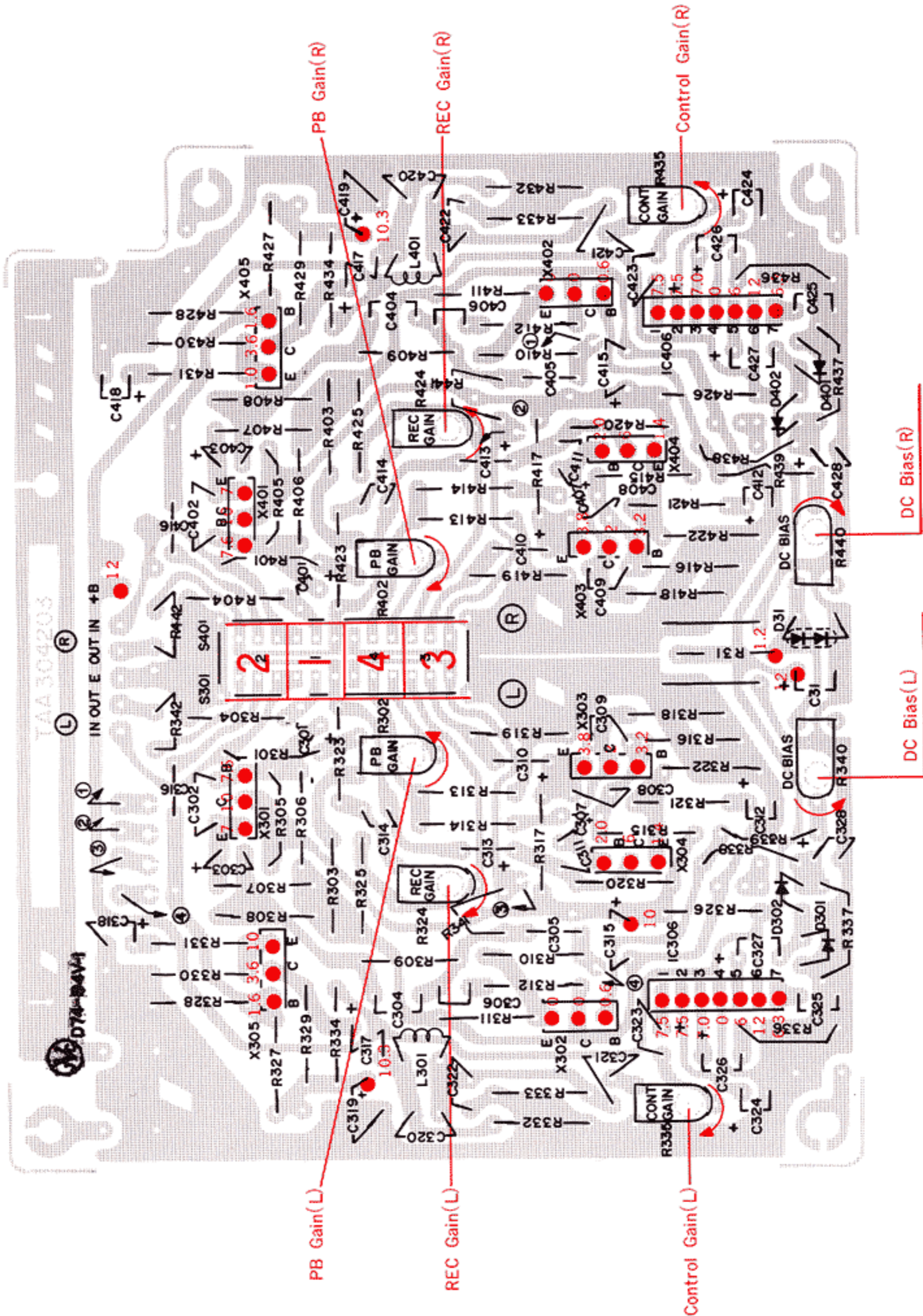

Fig. 35

ANRS Circuit Board Parts List

Ref. No.	Parts No.	Parts Name	Remarks	Q'ty
S301,401	*TAA304203-01	Circuit Board		1
	QSS8201-102	Slide Switch		1
	QMC0627-001	Plug Ass'y	6P	1
R31	*QMC0427-001	"	4P	1
	QRD142K-153	C. Resistor	15k Ω 1/4W	1
R301,401	" -273	"	27k Ω "	2
R302,402,324,424	QVP8A0B-014	V. Resistor	10k Ω B	4
R303,403	QRD142K-222	C. Resistor	2.2k Ω 1/4W	2
R304,404,308,408, 318,418,328,428, 338,438,339,439	" -473	"	47k Ω "	12
R305,405	" -104	"	100k Ω "	2
R306,406	" -334	"	330k Ω "	2
R307,407	" -822	"	8.2k Ω "	2
R309,409,316,416	" -274	"	270k Ω "	4
R310,410	" -100	"	10 Ω "	2
R311,411	" -562	"	5.6k Ω "	2
R312,412	" -181	"	180 Ω "	2
R313,413	" -683	"	68k Ω "	2
R314,414	" -102	"	1k Ω "	2
R315,415	" -564	"	560k Ω "	2
R317,417	" -154	"	150k Ω "	2
R319,419	" -823	"	82k Ω "	2
R320,420	" -103	"	10k Ω "	2
R321,421	" -101	"	100 Ω "	2
R322,422	" -332	"	3.3k Ω "	2
R323,423	" -183	"	18k Ω "	2
R325,425	" -392	"	3.9k Ω "	2
R326,426,334,434	" -122	"	1.2k Ω "	4
R327,427	" -224	"	220k Ω "	2
R329,429	" -472	"	4.7k Ω "	2
R330,430	" -681	"	680 Ω "	2
R332,432	" -123	"	12k Ω "	2
R333,433	" -103	"	10k Ω "	2
R335,435	QVP8A0B-024	V. Resistor	20k Ω B	2
R336,436	QRD142K-390	C. Resistor	39 Ω 1/4W	2
R337,437	" -333	"	33k Ω "	2
R340,440	QVP8A0B-015	V. Resistor	100k Ω B	2
R341,441	QRD143K-332	C. Resistor	3.3k Ω 1/4W	2
R342,442	" -822	"	8.2k Ω 1/4W	2
C31	QEW41CA-107	E. Capacitor	100 μ F 16V	1
C301,401,303,403	QEB41EM-335	LLC E. Capacitor	3.3 μ F 25V	4
C302,402	QCS11HK-561	Ceramic Capacitor	560PF 50V	2
C304,404	QFM41HK-223	Mylar Capacitor	0.022 μ F	2
C305,405	" -104	"	0.1 μ F	2
C306,406	" -183	"	0.018 μ F	2
C307,407	QEE41EM-105	Tantal E. Capacitor	1 μ F 25V	2
C308,408,321,421	QCS11HK-471	Ceramic Capacitor	470PF "	4
C309,409	" -101	"	100PF "	2
C310,410	QEE41EM-335	Tantal E. Capacitor	3.3 μ F "	2
C311,411	QCS11HK-270	Ceramic Capacitor	27PF 50V	2
C312,412,326,426	QEW41AA-476	E. Capacitor	47 μ F 10V	4
C313,413	QEW41CA-106	"	10 μ F 16V	2
C314,414	QCS11HK-181	Ceramic Capacitor	180PF 50V	2

Ref. No.	Parts No.	Parts Name	Remarks	Q'ty
C315,415	QEW41CA-476	E. Capacitor	47 μ F 16V	2
C316,416	QFM41HK-333	Mylar Capacitor	0.033 μ F 50V	2
C317,417	QEW41CA-475	E. Capacitor	47 μ F 16V	2
C318,418	QFM41HK-182	Mylar Capacitor	0.0018 μ F 50V	2
C319,419	QEW41CA-106	"	10 μ F 16V	2
C320,420	QCS11HJ-820	Ceramic Capacitor	82PF 50V	2
C322,422	QFM41HK-222	Mylar Capacitor	0.0022 μ F	2
C323,423	QEW41EA-105	E. Capacitor	1 μ F 25V	2
C324,424	QEW41AA-106	"	10 μ F 10V	2
C325,425	QCS11HK-271	Ceramic Capacitor	270PF 50V	2
C327,427,328,428	QEB41EM-105	LLC E. Capacitor	1 μ F 25V	4
L301,401	TAC000324-05	Inductor		2
X301,401,304,404	2SC1327(TU)	Transistor		4
X302,402	2SD545NP-V,S	"		2
X303,403	2SA721(TU)	"		2
X305,405	2SC828(R)	"		2
IC306,406	TA7066P(BC)	IC		2
D31	MA26W	Varistor Diode		1
D301,401,302,402	1S188FM	Diode		4

Check Circuit Board

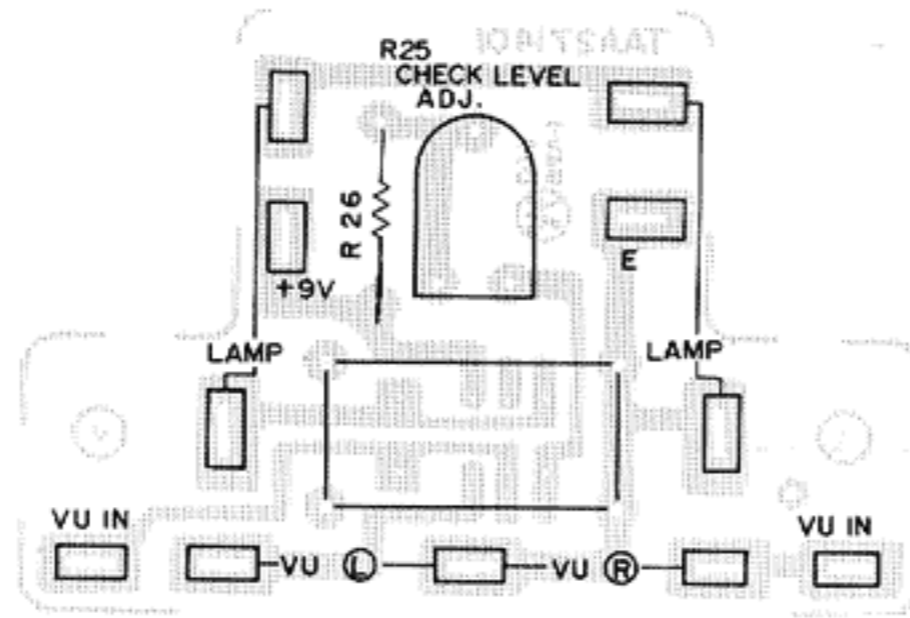

Fig. 36

Check Circuit Board Parts List

Ref. No.	Parts No.	Parts Name	Remarks	Q'ty
	TAA271401-01	Circuit Board		1
	E40516-001	Tab		12
R25	QSL2318-001	Lever Switch	for check	1
R26	QVP8A0B-024	V. Resistor	20k Ω B	1
	QRD142K-123	C. Resistor	12k Ω 1/4W	1
	T46729-002	Lamp	6.3V 70mA	2

Muting Circuit Board



Fig. 37

Mic Jack Circuit Board

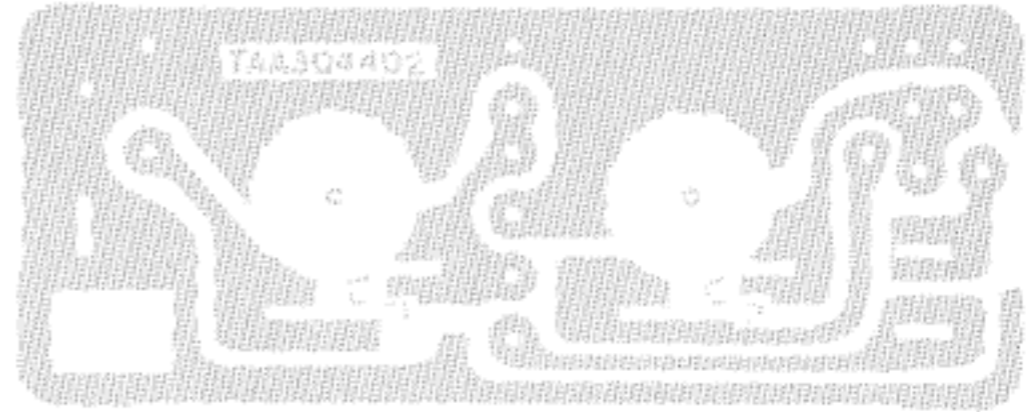

Fig. 38

Muting Circuit Board Parts List

Ref. No.	Parts No.	Parts Name	Remarks	Q'ty
	TAA271507-01	Circuit Board		1
	QSS4201-011	Slide Switch	for muting switch	1
R34	QRD143K-104	C. Resistor	100k Ω 1/4W	1
C32	QEW41CA-106	E. Capacitor	10 μ F 16V	1
X20	2SC1383(RS)	Transistor		1
X21	2SC828(RS)	"		1
	TFB271476-01	Switch Bracket		1
	SBSB3006Z	Tapping Screw		2
	WBS3000	T. Lock Washer		1

Mic Jack Circuit Board Parts List

Ref. No.	Parts No.	Parts Name	Remarks	Q'ty
	TAA304402-01	Circuit Board	for Mic jack	1
R148,248	QRD143K-822	C. Resistor	8.2k Ω 1/4W	2
C131,231	QCF11HP-222	Ceramic Capacitor	0.0022PF	2
C132,232	QCS11HK-821	"	820PF	2
R501,601	QRD143K-102	C. Resistor	1k Ω	2
C101,201	QCF41EZ-104	Ceramic Capacitor	0.1 μ F	2
	E40516-001	Tab		3

Switch Circuit Board

Red printed is shown the voltage (V) of playback mode.

() voltage; at recording mode.

When you measure the voltage by tester, we recommend you to use 20kΩ/V or more impedance tester.

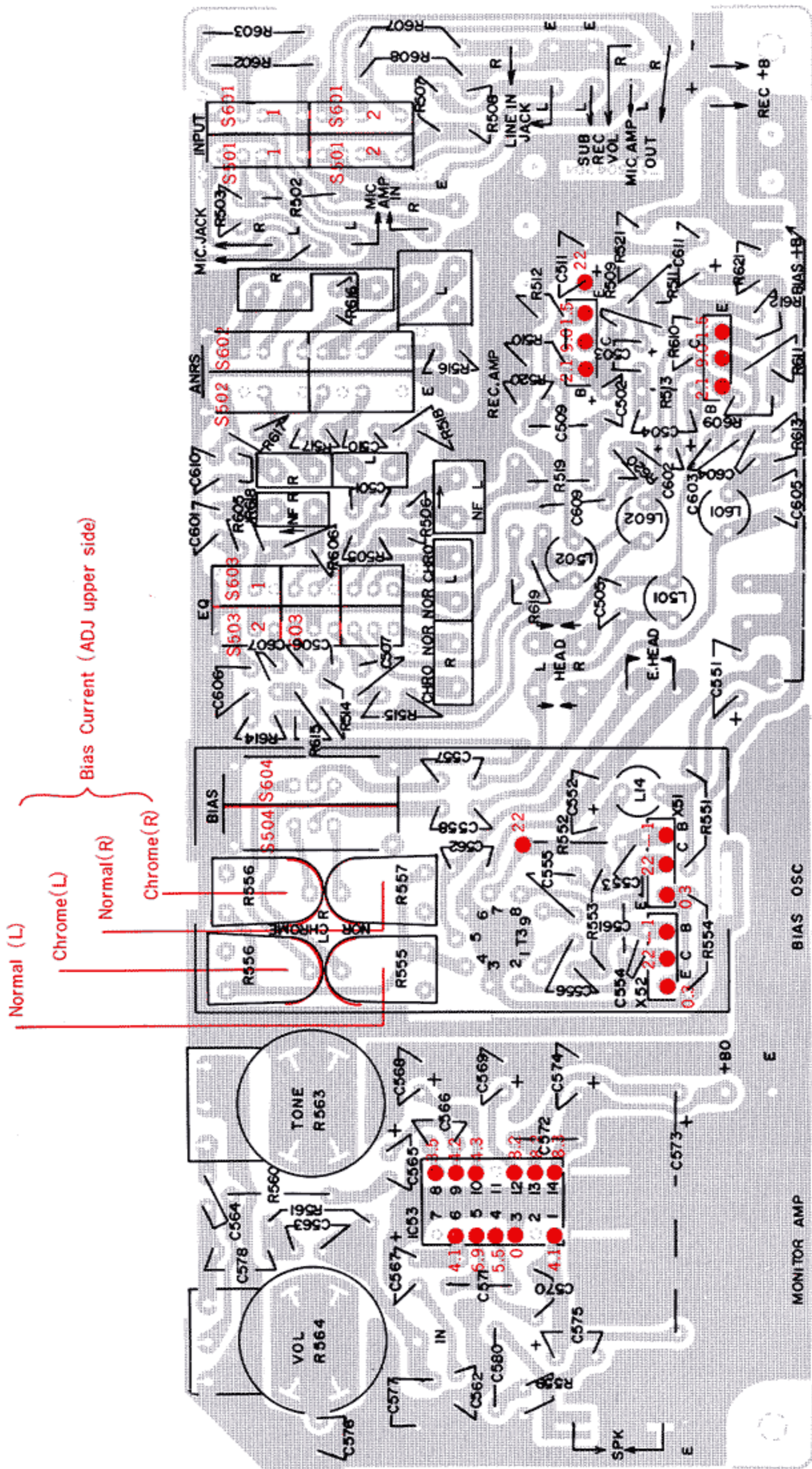

Fig. 39

Switch Circuit Board Parts List

Ref. No.	Parts No.	Parts Name	Remarks	Q'ty
	TAA304204-01	Circuit Board		1
	E43727-002	Lapping Pin		43
	E40516-001	Tab		2
	EG9010-001	"		1
	QSL4324-001	Lever Switch	for INPUT Select	1
	QSL4324-001	"	for ANRS	1
	QSL2218-112	"	for BIAS	1
	QSL6220-001	"	for EQ	1
	LPSP2606V	Screw	for SW	2
R563,564 (Rec Amp)	QVG9A2A-024	V. Resistor	20k Ω for Tone, Volume	2
R502	QRD143K-122	C. Resistor	1.2k Ω $\frac{1}{4}$ W	1
R602	QRD142K-122	"	1.2k Ω "	1
R503	QRD143K-103	"	10k Ω "	1
R603	QRD142K-103	"	10k Ω "	1
R505,605	QRD143K-222	"	2.2k Ω "	2
R506,606	-392	"	3.9k Ω "	2
R507,508	" -823	"	82k Ω "	2
R607,608	QRD142K-823	"	82k Ω "	2
R509,609	QRD143K-564	"	560k Ω "	2
R510,610	" -823	"	82k Ω "	2
R511,611	" -682	"	6.8k Ω "	2
R512,612	" -821	"	820 Ω "	2
R513,613	" -153	"	15k Ω "	2
R514,614,515,615	" -560	"	56 Ω "	4
R516,616	" -472	"	4.7k Ω "	2
R517,617	" -564	"	560k Ω "	2
R518,618	" -122	"	1.2k Ω "	2
R519,619	" -103	"	10k Ω "	2
R520,620	" -273	"	27k Ω "	2
R521,621	" -681	"	680 Ω "	2
C501,601	QFM41HJ-153	Mylar Capacitor	0.015 μ F 50V	2
C502,602	QEW41CA-106	E. Capacitor	10 μ F 25V	2
C503,603	QEB41HM-684M	"		2
C504,604	QFM41HK-122	Mylar Capacitor		2
C505,605	QCS12HJ-151	Ceramic Capacitor	150PF 500V	2
C506,606	QFM41HJ-153	Mylar Capacitor	0.015 μ F 50V	2
C507,607	" -183	"	"	2
C509,609	QFM41HK-154	"	"	2
C510,610	-562	"	"	2
C511,611	QFM41HJ-152	"	0.0056 μ F "	2
L501,601	TAC000324-01	Inductor	18mH	2
L502,602	TAC000324-04	"	5.6mH	2
X501,601 (Bias OSC Circuit)	2SC828A(R)	Transistor		2
T3	TAB265401-01	OSC Coil		1
R551	QRD146K-151	C. Resistor	150 Ω $\frac{1}{4}$ W	1
R552,553	QRD142K-104	"	100k Ω	2
R554	" -220	"	22 Ω $\frac{1}{4}$ W	1
R555,557	QVP8A0B-025	V. Resistor		2
R556,558	" -015	"		2
C551	QEW41EA-105	E. Capacitor	10 μ F 50V	1
C552	" -335	"	3.3 μ F "	1

Ref. No.	Parts No.	Parts Name	Remarks	Q'ty
C553,554	QCS11HK-391	Ceramic Capacitor	390PF 50V	2
C555,556	QFM41HK-272	Mylar Capacitor	0.0027 μ F "	2
C557,558	QCS12HK-221	Ceramic Capacitor	220PF 500V	2
C561	QEZ0001-472	Polypropylene Capacitor	0.047 μ F	1
C562	" -822	"	0.0082 μ F	1
L14	T40442-002	Inductor	1mH	1
X51,52	2SC828A(RS)	Transistor		2
	TAS271320-01	OSC Case (A)		1
	TAS271479-01	" (B)		1
(Monitor Amp)				
R559	QRD143K-4R7	C. Resistor	4.7 Ω 1/4W	1
R560	QRD142K-221	"	220 Ω	1
R561	" -273	"	23k Ω 1/4W	1
R562	QRD143K-471	"	470 Ω	1
C563	QFM41HK-272	Mylar Capacitor	0.0027 μ F 50V	1
C564	" -123	"	0.012 μ F "	1
C565	QEW41EA-105	E. Capacitor	1 μ F 25V	1
C566	QCF11HP-102	Ceramic Capacitor	1000PF 50V	1
C567	QEW41CA-226	E. Capacitor	22 μ F 16V	1
C568	QEW41AA-227	"	220 μ F "	1
C569	" -106	"	10 μ F "	1
C570,571	QCS11HK-561	Ceramic Capacitor	560PF 50V	2
C572	QFM41HK-154	Mylar Capacitor	0.15 μ F "	1
C573	QEW21AA-476	E. Capacitor	47 μ F 16V	1
C574	QEW41AA-227	"	220 μ F 10V	1
C575	" -477	"	470 μ F "	1
C576	QCF11HP-103	Ceramic Capacitor	0.01 μ F 50V	1
IC53	LA4102	IC		1
C577	QCS11HK-471	Ceramic Capacitor	470PF 50V	1
C578	QFM41HK-153	Mylar capacitor	0.015 μ F "	1
C580	QCF41EZ-104	Ceramic Capacitor	0.15 μ F "	1
	QMC0657-001	Socket Ass'y	6P	1
	*QMC0457-001		4P	1

Mechanical Components

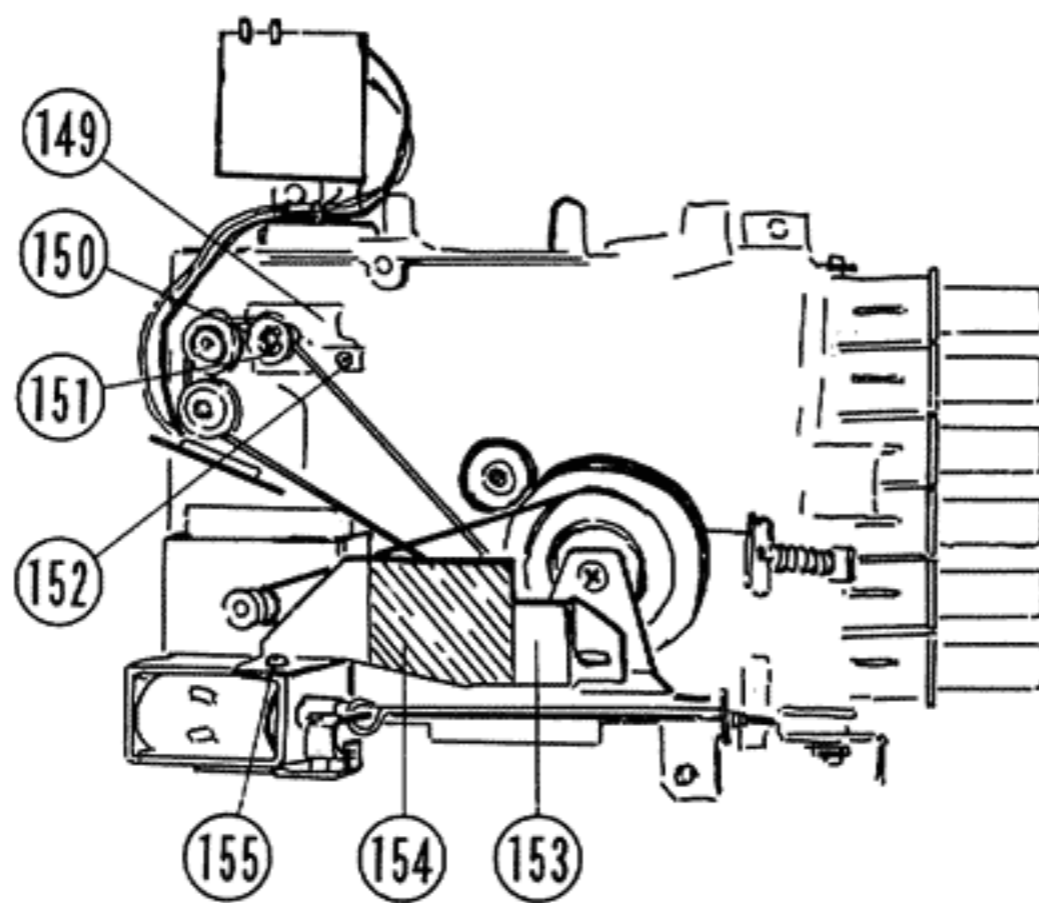
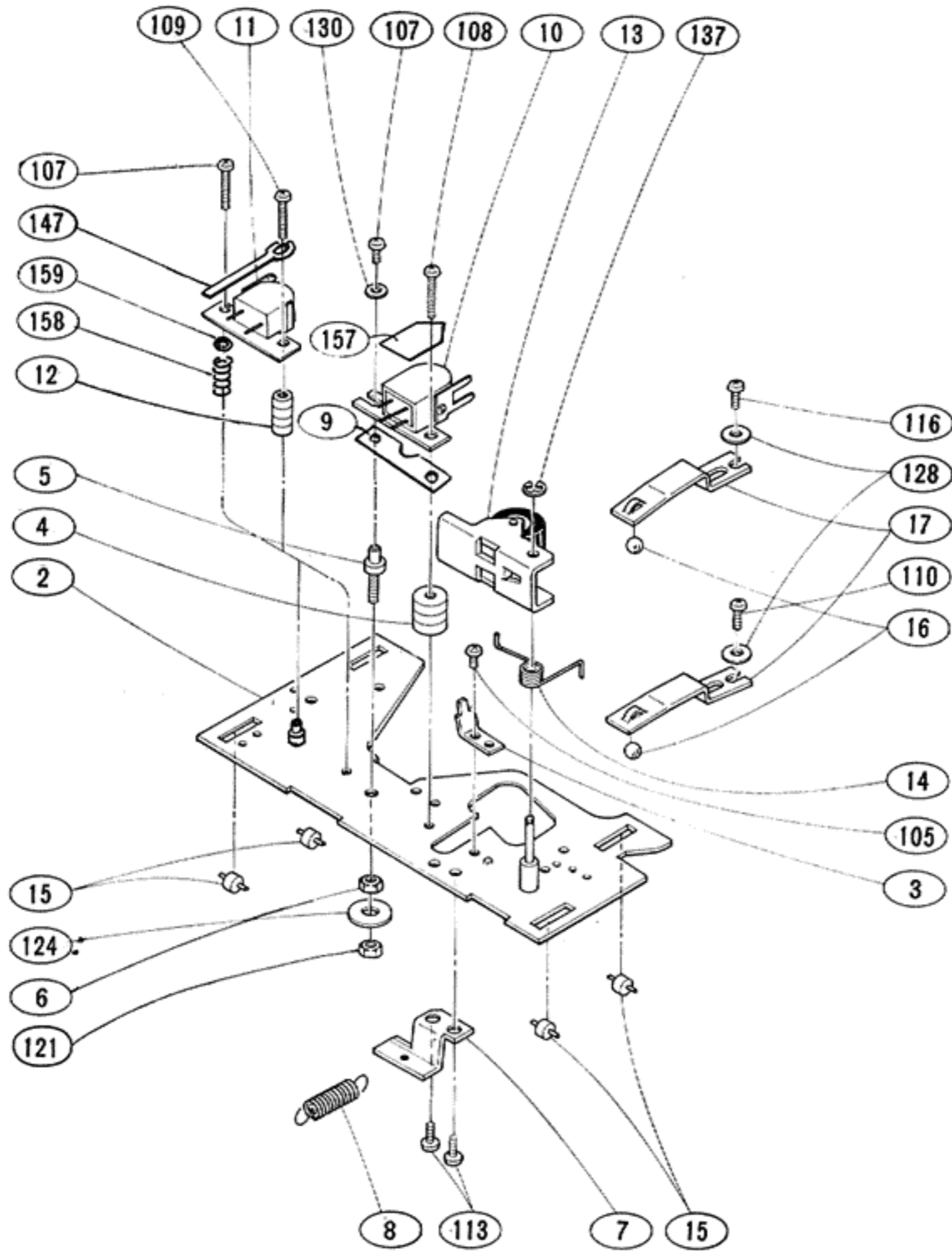

Fig. 40

Mechanical Component List

Ref. No.	Parts No.	Parts Name	Remarks	Q'ty
1	T30987-00F	Chassis Base Ass'y		1
2	T43081-00D	Head Panel Ass'y		1
3	T43080-001	Bracket		1
4	T45799-004	Head Stud		1
5	T42045-001	"		1
6	T42046-001	Special Nut		1
7	TFB267475-01	Head Panel Bracket		1
8	160508T	Spring		1
9	1310403T	R.P. Head Spring		1
10	THC037407-0A	R.P. Head Ass'y		1
11	THS265480-0A	E. Head Ass'y		1
12	TFH267424-03	E. Head Stud		1
13	3050485ZT	Pinch Roller Arm Ass'y		1
14	T45138-001	Pinch Roller Spring		1
15	T42057-001	Head Panel Roller		4
16	T41615-003	Bowl Bearing	3mm	2
17	2010303T	Head Panel Spring		2
18	T42674-00A	Reel Disk Ass'y (2)		1
19	TEP267464-01	Counter Drive Pulley		1
20	T42059-00C	Reel Disk Ass'y		1
21	T42051-009	Spring		1
22	TGT271322-0A	Push Button Case Ass'y		1
23	TJB271314-01	Push Button Base		6
24	TJB271506-0A	Push Button Ass'y		4
25	" -0B	"		1
26	" -0C	"		1
27	T30300-135	Spring	for Cam	1
28	T45809-001	Capstan Metal Ass'y		1
29	T42071-001	Metal Stopper		1
30	T30300-120	Spring	Pause Lever – Button Lever	1
31	T43084-00C	Lever Ass'y		1
32	4180408T-01	Lock Plate		1
33	T43070-001	Spring		1
34	T42049-003	"		1
35	TEW267429-0D	Flywheel Ass'y		1
36	TFB267474-02	Flywheel Holder		1
37	2380905T	Thrust Bearing		1
38	T42076-001	Brake Arm Spring		6
39	T42077-001	Brake Arm Shaft		4
40	T42075-001	Brake Arm		1
41	TGP000465-0B	Take Up Idler Arm Ass'y		1
42	T45139-01	Take Up Wheel Spring		1
43	T42088-001	Brake Bar		1
44	TFB267511-0A	F.F. Idler Arm Ass'y		1
45	T30300-120	Spring	F.F. Idler – F.F. Lever	1
46	T42049-003	"	Brake Bar - F.F. Idler Arm	1
47	5850801T	"	F.F. Idler – F.F. Lever	1
48	T45822-002	F.F. Arm Guide Plate		1
49	T42049-023	Spring	Brake Bar – F.F. Idler Arm	1
50	T42098-00D	Rew Arm Ass'y		1
51	T42049-009	Spring	Brake Bar – REW Idler Arm	1
52	T45717-001	Kick Lever		1
53	T42105-001	Metal		1
54	T42106-001	Rec Rod		1
55	T42107-001	Rec Lever		1
56	T42105-001	Metal		1
57	T41049-005	Spring		1
58	T40173-019	Cushion		1
59	T42109-001	F.F. Shaft		1

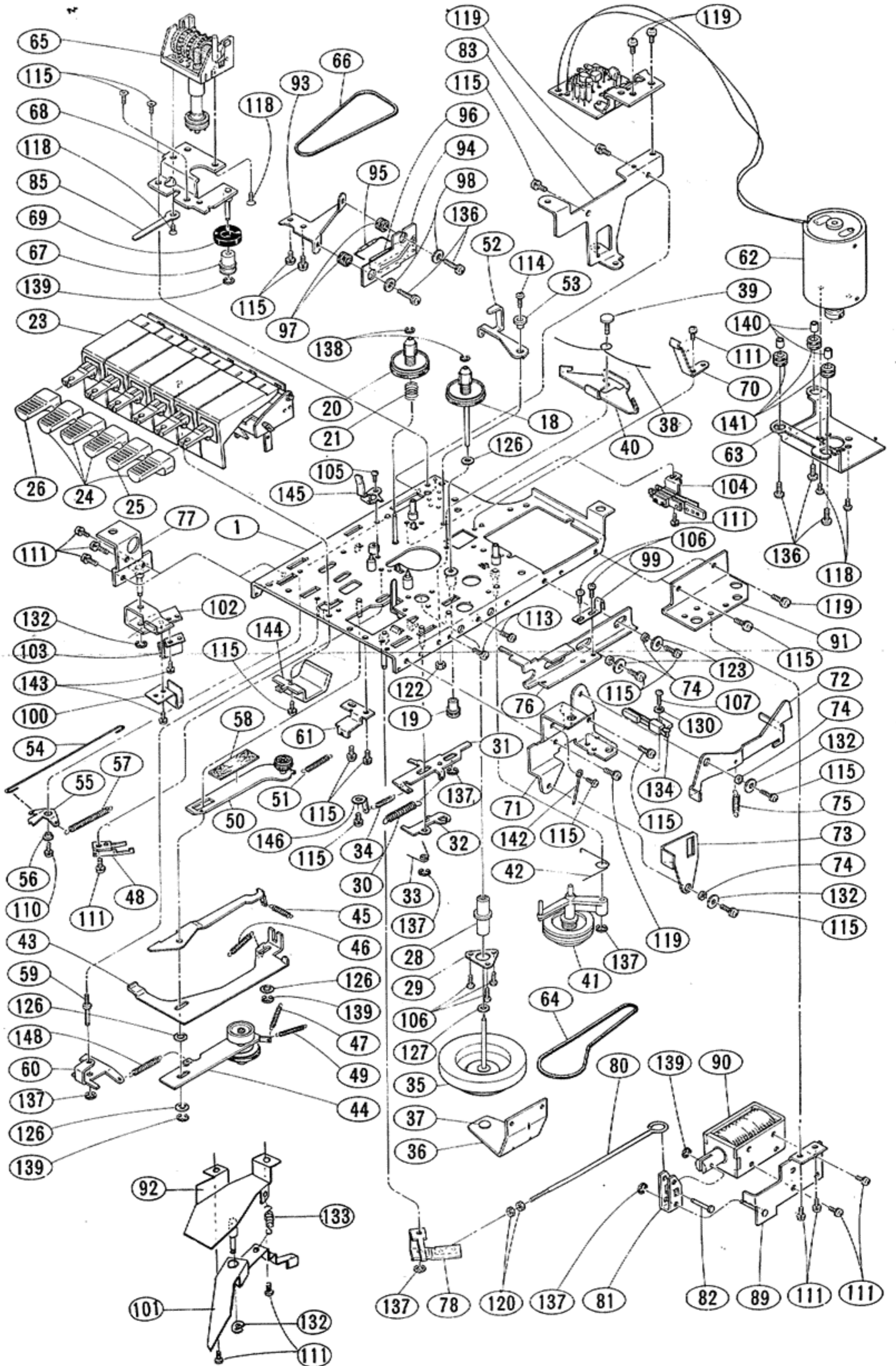

Fig. 41

Ref. No.	Parts No.	Parts Name	Remarks	Q'ty
60	T43654-002	F.F. Lever (3)		1
61	T43068-001	Bracket		1
62	m207-00B	Motor Ass'y		1
63	TFB271487-01	Motor Bracket		1
64	TEB000464-02	Capstan Belt		1
65	*TGN304302-0A	Counter Ass'y		1
66	T45786-002	Counter Belt		1
67	TGP271512-0B	Magnet Pulley Ass'y		1
68	TGB271513-0A	Counter Bracket Ass'y		1
69	TDZ271434-01	Magnet		1
70	T1490105T-002	Spring Plate	for Eject	1
71	TFB271446-01	Eject Lever Bracket		1
72	TFB271447-01	Eject Lever		1
73	TFB271448-01	Eject Kick Lever		1
74	T30302-036	Coller		4
75	481008T-01	Spring		1
76	TFB271449-01	Slide Bar		1
77	TFB271457-0A	Record Bracket Ass'y		1
78	TFB271470-01	Auto Stop Lever		1
79	T30300-081	Spring	for Auto Stop Lever	1
80	TFW271475-01	Auto Stop Rod		1
81	TFB271472-01	Auto Stop Arm		1
82	TFH271471-01	Rod		1
83	TFB271315-01	C. Board Bracket		1
84	S4709-001	Wire Clamp		1
85	04224-0-2	Vinyl Tube		1
86	04225-L-1.7	"		1
87	04224-L-1.7	"		2
88	T30301-100	Spring	for Solenoid	1
89	TFB271500-0A	Solenoid Bracket Ass'y		1
90	T44546-001	DC. Solenoid		1
91	TFB271450-01	Side Bracket		1
92	TFB271456-0A	Bracket Ass'y	ANRS	1
93	TFB271413-01	Read Switch Bracket		1
94	TAA271402-01	Read Switch C. Board		1
95	TDS271409-01	Read Switch		1
96	TER271414-01	Spacer		1
97	53492	Rubber Bushing		4
98	T30302-063	Coller		2
99	TFP271491-01	Switch Spring		1
100	TFP271490-01	ANRS Spring Plate		1
101	TFB271453-01	Record Lever	for ANRS	1
102	TFB271458-01	"	for REC/PB	1
103	TFP271498-01	REC Spring Plate		1
104	T30515-00B	Switch Ass'y	for Power SW	1
105	SPSP2003Z	Screw		1
106	SPSP2004Z	"	for SW Spring	1
107	SPSP2006Z	"	for Power SW	2
108	SPSP2010Z	"		1
109	SPSP2014Z	"		1
110	SPSP2604Z	"		1
111	LPSP2604Z	"	ANRS Spring Plate, Muting SW Motor SW, FF Arm Guide Plate	9
112	SPSP2605Z	"		2
113	LPSP2605Z	"	Flywheel Holder	6
114	SPSP2606Z	"	Kick Lever	6
115	LPSP2606Z	"	Lead SW Bracket	3
116	SPSP2608Z	"		1
117	SPSP2610Z	"		2

Ref. No.	Parts No.	Parts Name	Remarks	Q'ty
118	SPSP3004ZS	Screw		5
119	LPSP3006ZS	"		4
120	NNB2000	Nut		2
121	NNB2600N	"		1
122	NTB2600N	"	Brake Arm	1
123	Q03091-130	Washer		4
124	Q03091-150	"		1
125	Q03093-115	"		2
126	Q03093-609	"		4
127	Q03093-612	"		1
128	WNB2600N	"		2
129	WNS3000Z	"		3
130	WNE2000	"	Pause SW, SW Spring	4
131	WNB2600	"	Lead SW Plate	2
132	REE3000	E. Ring	Record Lever	2
133	T30300-131	Spring	ANRS Record Lever	1
134	TDS000334-02	Switch	Pause SW	1
135	SPSP2008Z	Screw	"	1
136	LPSP2610Z	"	Lead SW Plate, Motor Bracket	5
137	REE2000	E. Ring	Lock Plate, Takeup Ass'y, Pinch Roller, Lever Ass'y	4
138	REE1200	"	Reel Disk	2
139	REE1500	"	Brake Bar	4
140	581009T	Collar		3
141	581006T	Motor Rubber		3
142	T43088-001	Spring		1
143	LPSP2504Z	Screw		2
144	TFB271486-01	Button Case Bracket		1
145	T44181-001	Cassette Guide		1
146	021502T	Lug		1
147	T65640-001	Wire Clamp		1
148	T42049-008	Spring		1
149	TGB271514-0A	Pulley Bracket Ass'y		1
150	TGP271512-0A	Magnet Pulley Ass'y		1
151	REE2000	E. Ring		1
152	LPSP2004Z	Screw		1
153	TAS271505-01	Shield Plate		1
154	TJN271504-01	Spacer		1
155	LPSP2603Z	Screw		1
156	Q04109-0-0.7	Vinyl Tube		1
157	THC037417-01	Head Plate		1
158	480408T	Head Spring		1
159	WNS2000N	Washer		1

Enclosure Assembly

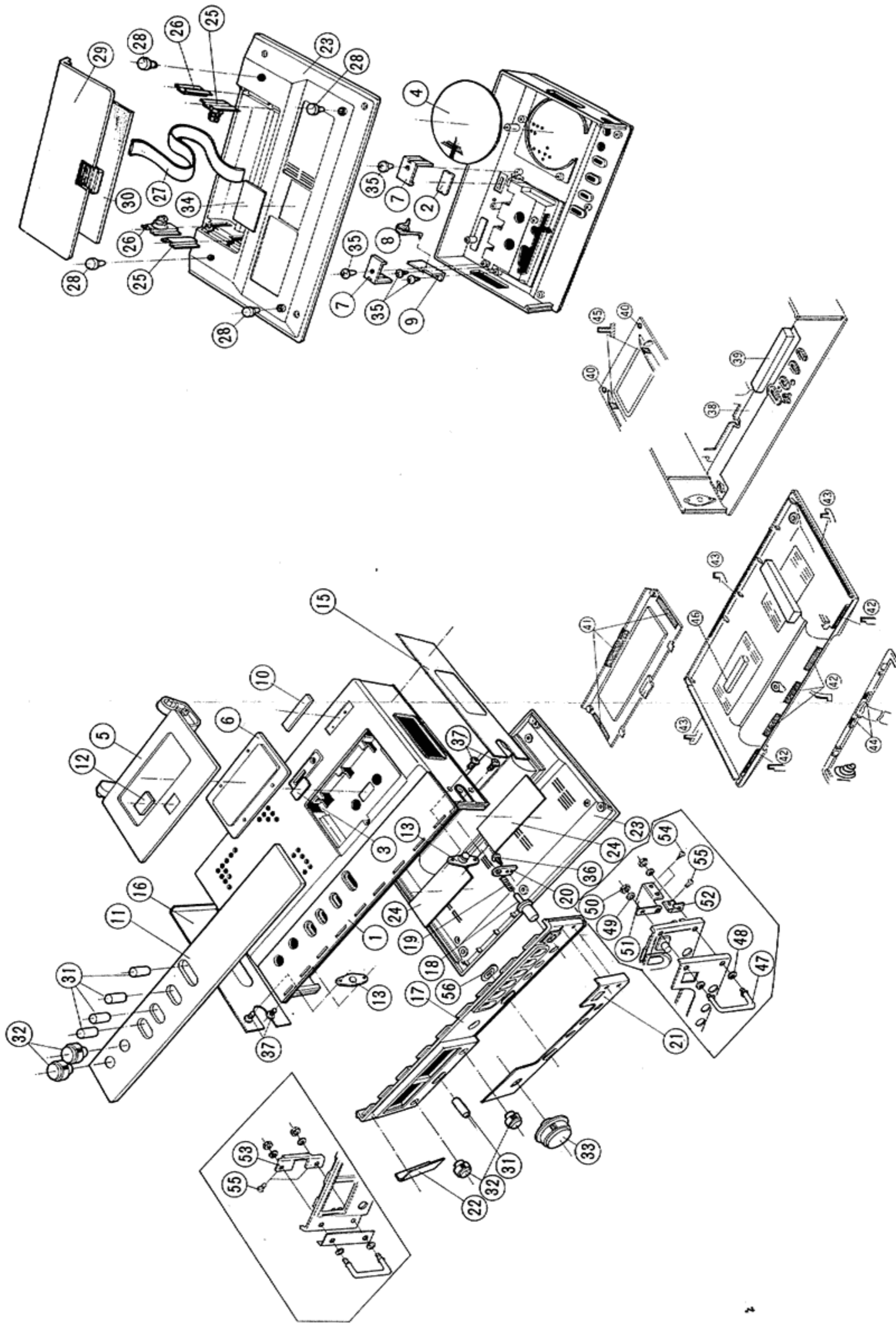

Fig. 42

Ref. No.	Parts No.	Parts Name	Remarks	Q'ty
47	TJL271494-01	Label (B)	for ANRS C. Board	1
48	QCF11HP-103	Ceramic Capacitor	C30 0.01 μ F Master Volume	1
49	QRD143K-822	C. Resistor	8.2k Ω	2
50	QCF11HP-103	Ceramic Capacitor	Left Bracket & Jack	1
51	53492	Rubber Bushing		2
52	50242-2	Lug		1
53	LPSP2606Z	Screw	for SW Bracket, Switch	4
54	TAZ000452-02	Seal	CD-1635-2E	1
	" -03	"	CD-1635-2B	1
55	TAS286401-01	Shield Plate	for Power Transformer CD-1635-2A/B/E	1
56	F4932-002	Special Washer	for Power Transformer	2
57	T42693-00B	Terminal	CD-1635-2B	1
58	FG9060-001	Wire Connector	CD-1635-2E	1
59	S4709-002	Wire Clamp	CD-1635-2B	1
60	SPKP3008S	Screw	for Heat Sink Terminal, CD-1635-2B	1 2
61	SPBP2610B	"	for AC Jack, CD-1635-2B/E	2
62	TAA305459-01	C. Board	for PIN Jack	1
63	TFB288401-01	Socket Bracket	CD-1635-2U	1
64	LPSP3006Z	Screw	for Bracket, CD-1635-2U	2
65	QMC0306-001	Plug Ass'y	CD-1635-2U	1
66	QMC0733-001	Socket Ass'y	CD-1635-2U	1
67	LPSP3008ZS	Screw	for Socket, CD-1635-2U	2

Electrical Parts Except Circuit Board Parts

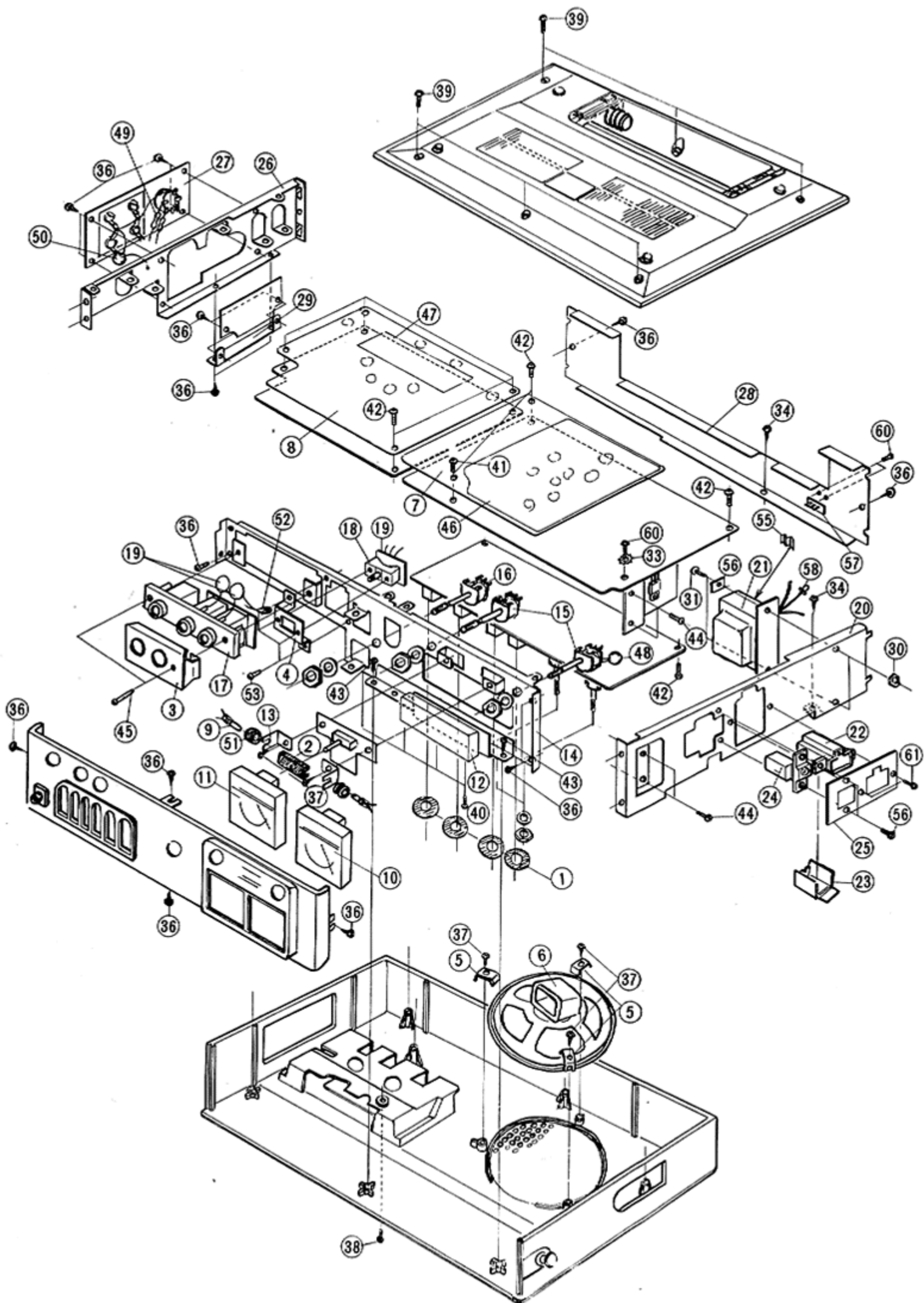
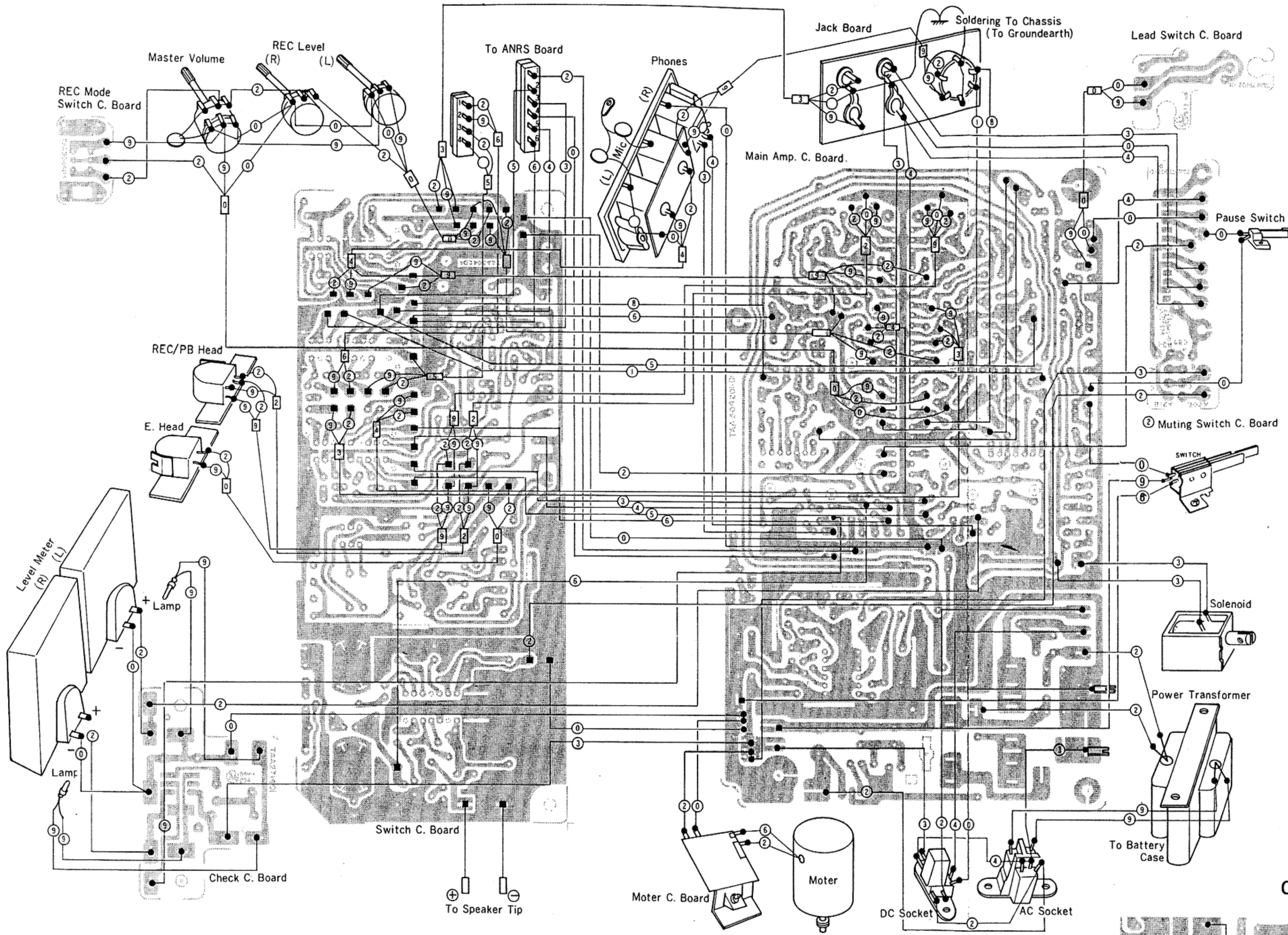

Fig. 43

Wiring



- Color code are shown below
- 1 Brown
 - 2 Red
 - 3 Orange
 - 4 Yellow
 - 5 Green
 - 6 Blue
 - 7 Violet
 - 8 Grey
 - 9 White
 - 0 Black

CD-1635-2A

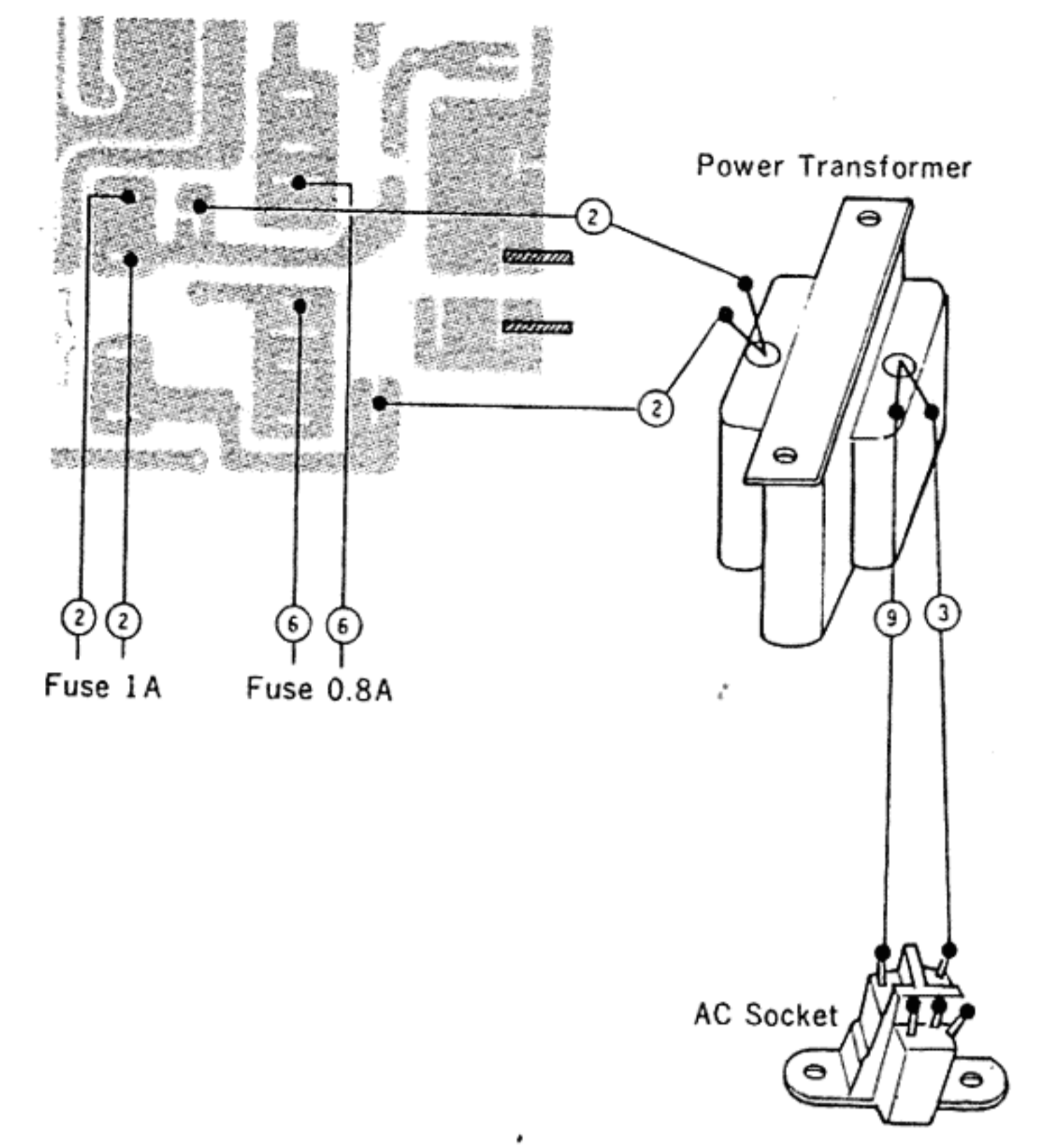

CD-1635-2B

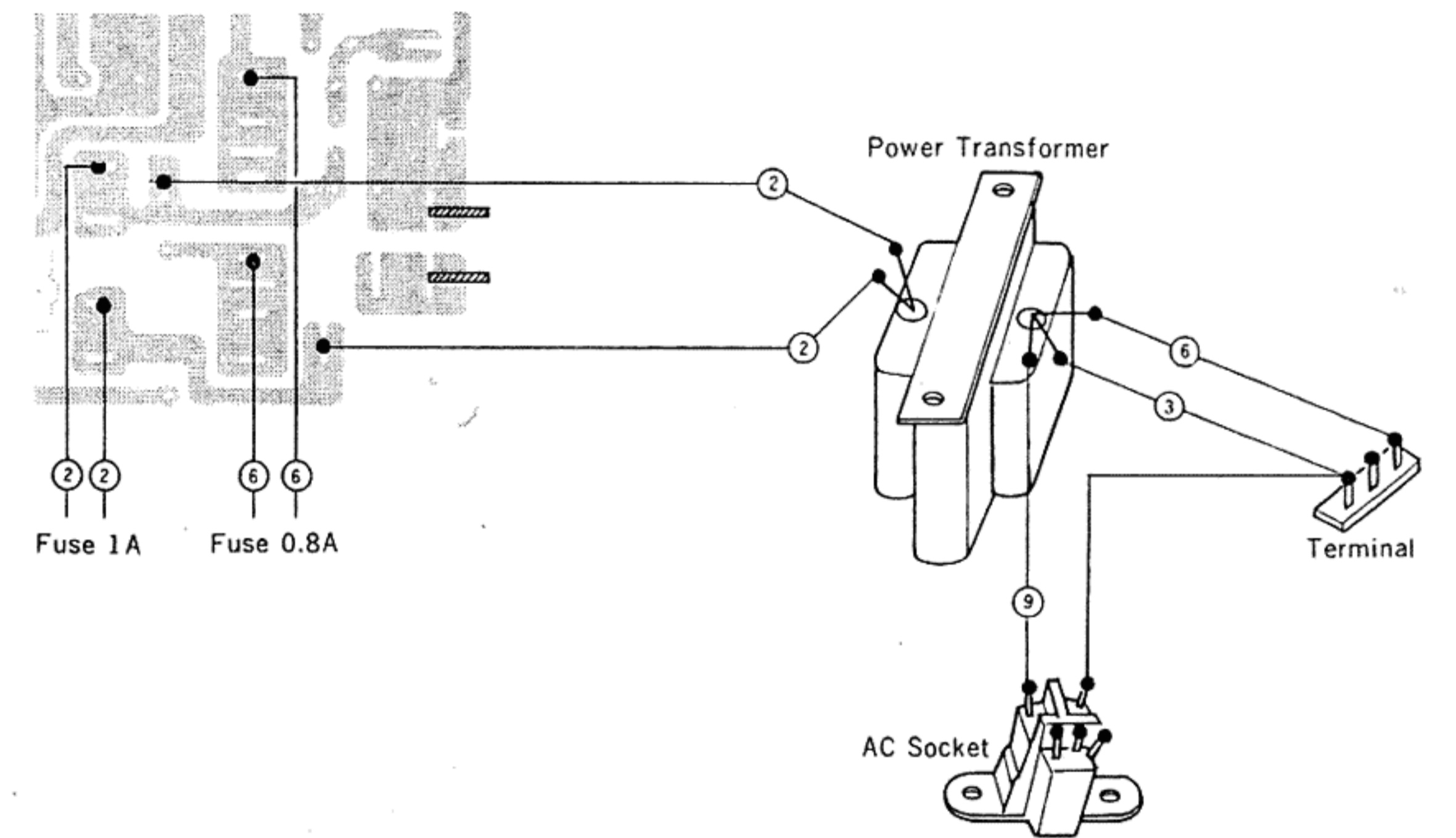

CD-1635-2U

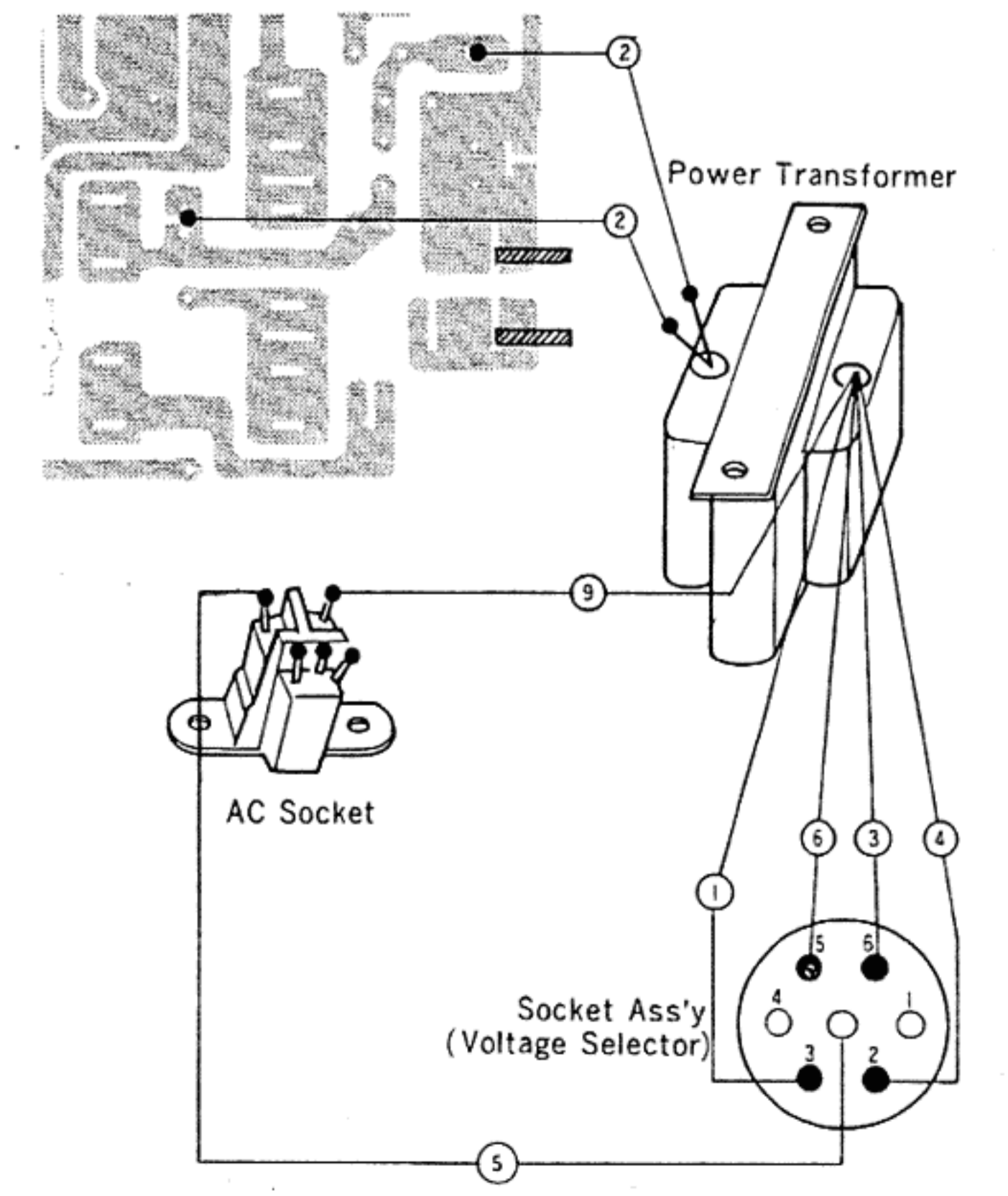

CD-1635-2E

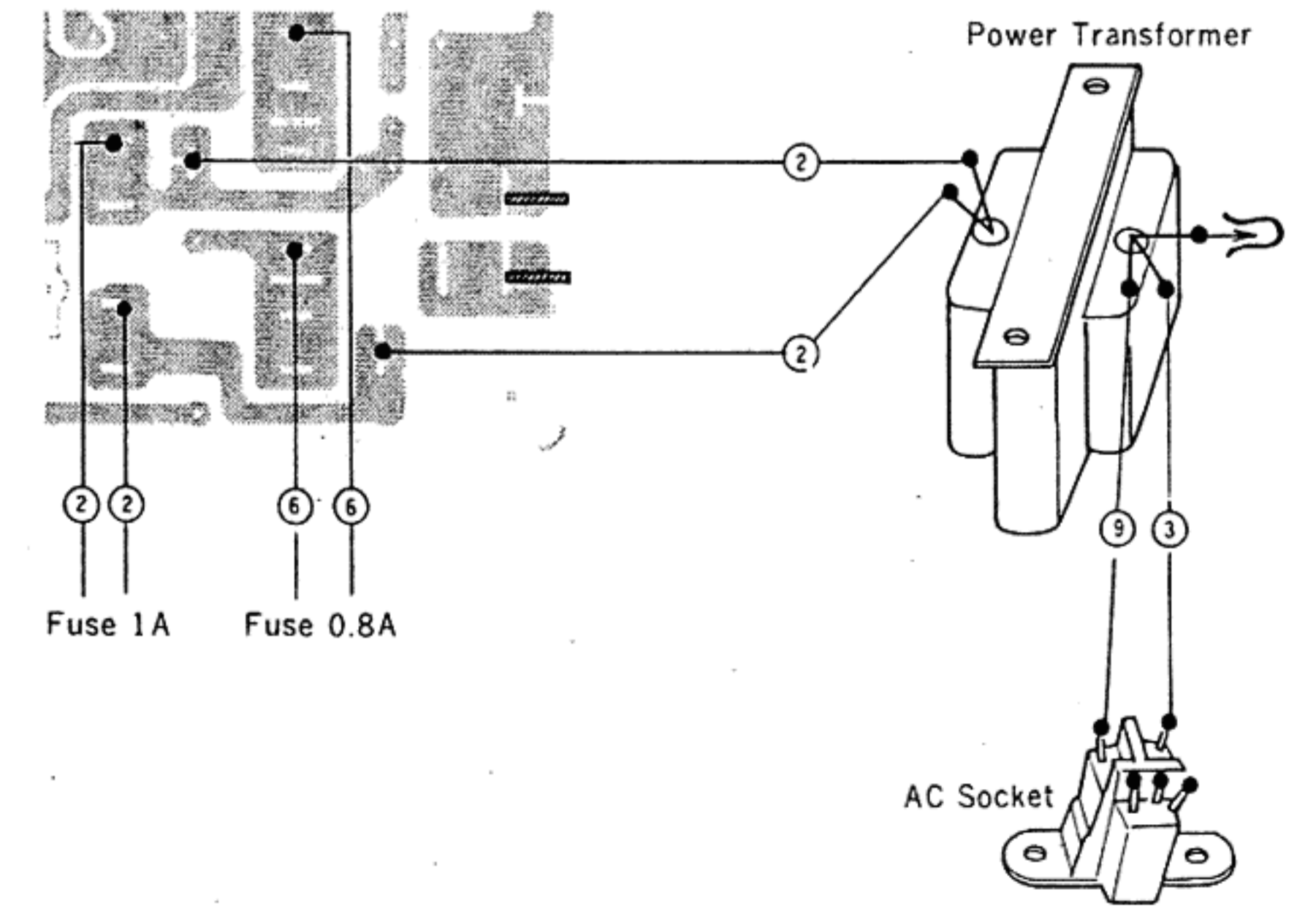

CD-1636/C

Fig. 44

Standard Schematic Diagram of CD-1635Mark II & CD-1636

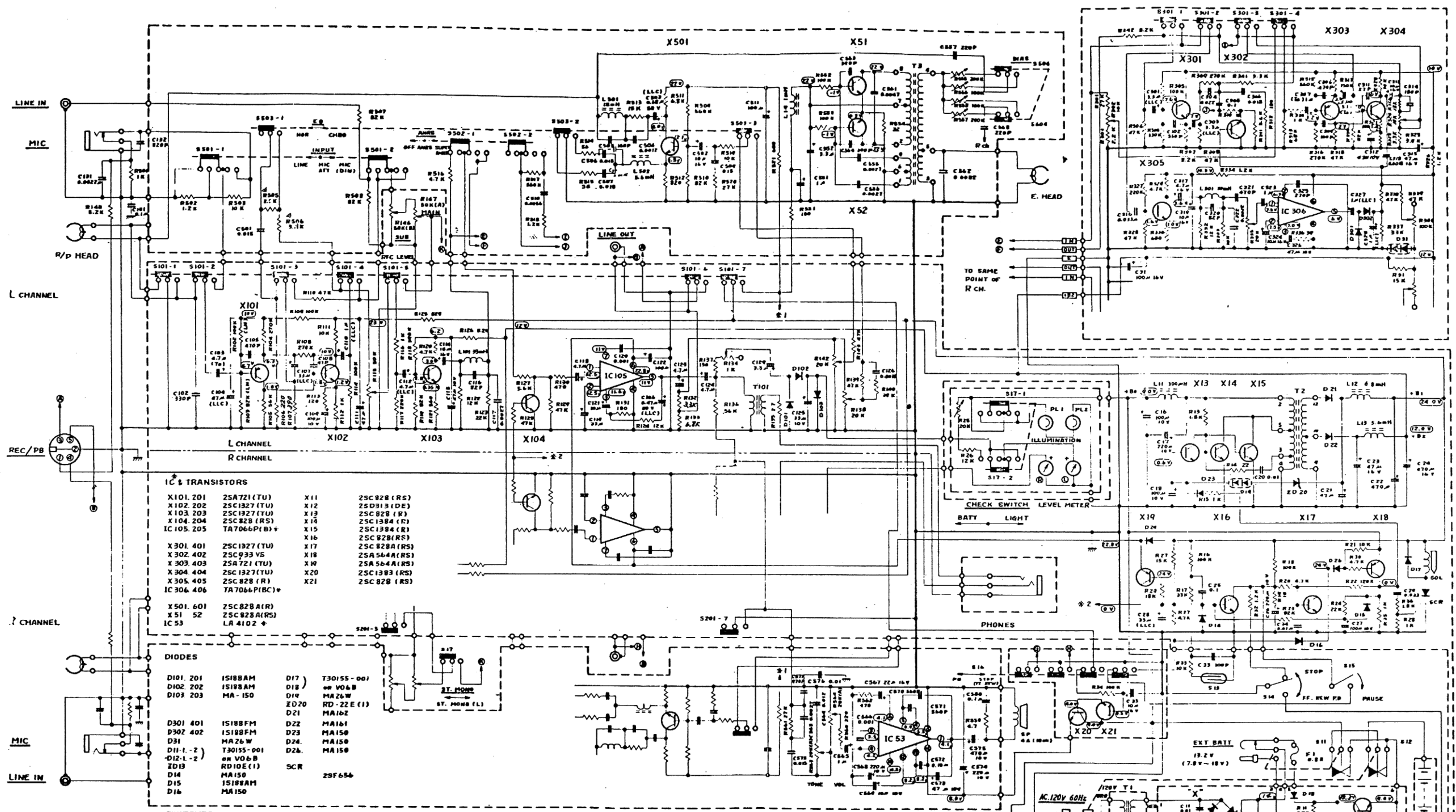

IC & TRANSISTORS

X101. 201	25A721 (TU)	X11	25C92B (RS)
X102. 202	25C1327 (TU)	X12	25D313 (DE)
X103. 203	25C1327 (TU)	X13	25C828 (R)
X104. 204	25C828 (RS)	X14	25C1394 (R)
IC 105. 205	TA7066P(B)	X15	25C1394 (R)
X301. 401	25C1327 (TU)	X16	25C92B (RS)
X302. 402	25C933 (VS)	X17	25C828A (RS)
X303. 403	25A721 (TU)	X18	25A564A (RS)
X304. 404	25C1327 (TU)	X19	25A564A (RS)
X305. 405	25C828 (R)	X20	25C1393 (RS)
IC 306. 406	TA7066P(BC)	X21	25C828 (RS)
X501. 601	25C828A (R)		
X51. 52	25C828A (RS)		
IC 53	LA 4102		

DIODES

D101. 201	1S188AM	D17	T30155-001
D102. 202	1S188AM	D18	OR VO&B
D103. 203	MA-150	D19	MA26W
		D20	RD-22E (1)
		D21	MA16Z
D301. 401	1S188FM	D22	MA161
D302. 402	1S188FM	D23	MA150
D31	MA26W	D24	MA150
D11-1, -2	T30155-001	D25	MA150
D12-1, -2	OR VO&B		
D13	RD10E (1)	SCR	2SF654
D14	MA150		
D15	1S188AM		
D16	MA150		

SWITCHES

S101-1 ~ -7	REC - PB ... PB	S11	EXT. BATT JACK
S301-1 ~ -4	REC - PB ... PB	S12	AC JACK
S401	(401)	S13	REED SWITCH
S501-1, -2	INPUT ... LINE	S14	POWER
S502-1, -2	ANRS ... OFF	S15	PAUSE
S503-1 ~ -3	EQ ... NOR	S16	MUTING
S504	BIAS ... NBR	S17	ST-MONO ... ST.
S17-1, -2	CHECK ... OFF		

Note:
All rated voltages of electrolytic capacitor are 25V unless otherwise specified.

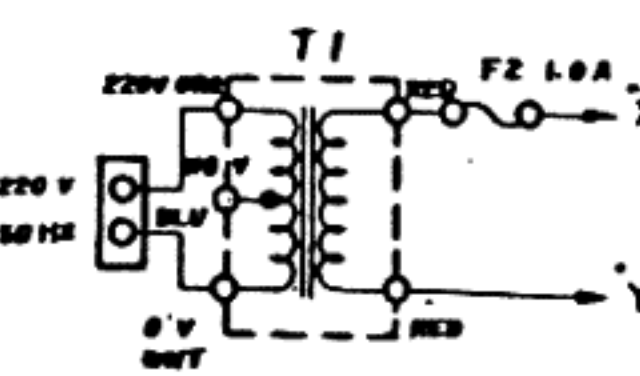
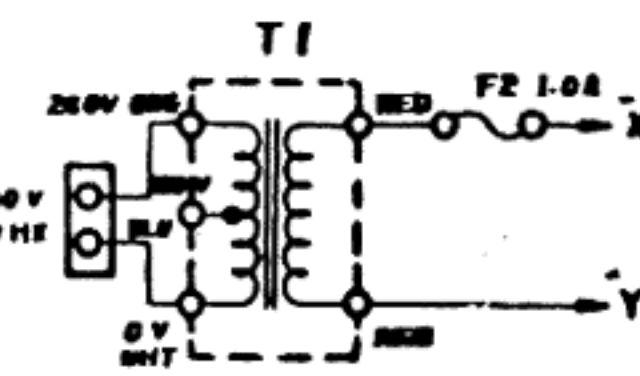
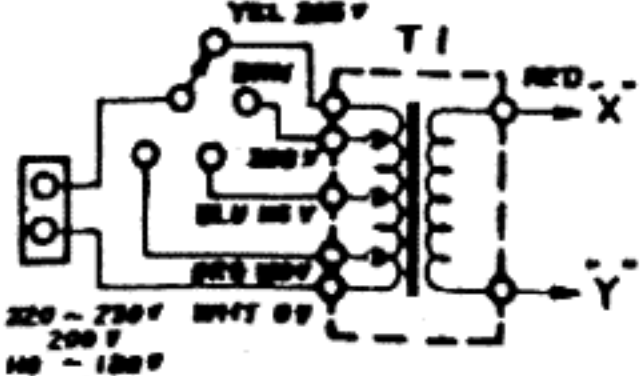
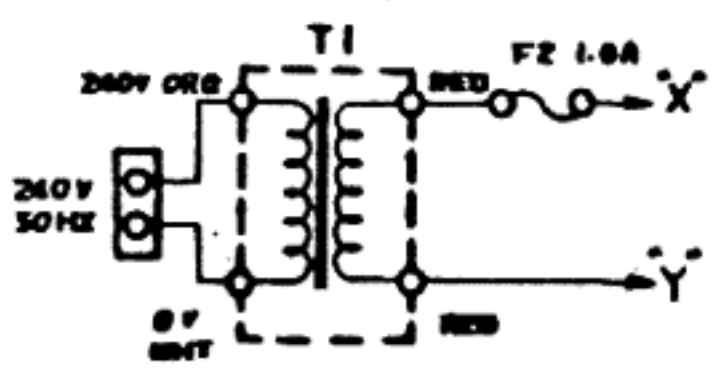

CD-1635-2A

CD-1635-2U

CD-1635-2B

CD-1635-2E

PT. NO.	-00A	-00B	-00C	-00D	-00E
POWER SUPPLY SECTION	Fig 1	Fig 2	Fig 3	Fig 4	Fig 5
MODEL	CD1636	CD1636C	CD1636B	CD1636U	CD1636A

Accessories

Parts No.	Parts Name	Remarks	Q'ty
T46965-002	Demo Cassette	(DT-626)	1
T30046-00B	Pin Cord Ass'y	CD-1636/C, CD-1635-2A/U	2
CN201	DIN Cord Ass'y	CD-1635-2B/E	1
T47796-00B	Head Cleaning Stick		2
AP4056A-024	Envelope	for H.C. Stick	1
TLT000429-01	Caution Card		1
QMP2540-183	Power Cord	CD-1635-2A	1
QMP9017-006	"	CD-1635-2B	1
QMP1240-183	"	CD-1636/C	1
QMP3950-183	"	CD-1635-2E	1
QMP7640-183	"	CD-1635-2U	1
TLC271319-0B	Band Ass'y		1
TJL000476-02	ANRS Seal		1
TJL000477-02	Super ANRS Seal		1
T7405E	Instruction Book	CD-1636	1
T7446EGF	"	CD-1635-2A/B/E/U	1
T7566EF	"	CD-1636C	1
T30994-037	Feature Tag	CD-1636	1
BT20029	Warranty Card	CD-1635-2A	1
TLT052401-01	Warning Label	CD-1635-2A/B/E	1
TLT000443-01	Seal	CD-1635-2A/B/E/U, CD-1636/C	1
BT20013	Guarantee Certificate	CD-1635-2B	1
QZL1002-003	Warning label	for P. Cord, CD-1635-2B	1
TLT000462-02	B.S. Caution	for 2-cove Cord, CD-1635-2B	1
T46328-003	Caution Card	CD-1635-2B	1
T46328-001	"	CD-1635-2U	1
BT20025	Warranty Card	CD-1636C	1
T44362-001	CSA Marker	CD-1636C	1
TLT279401-01	Caution Label	CD-1635-2E (for French market)	1
QZL1031-001	SEV Seal	CD-1635-2E	1
TLT279402-01	SS Label	CD-1635-2E	1

Packing

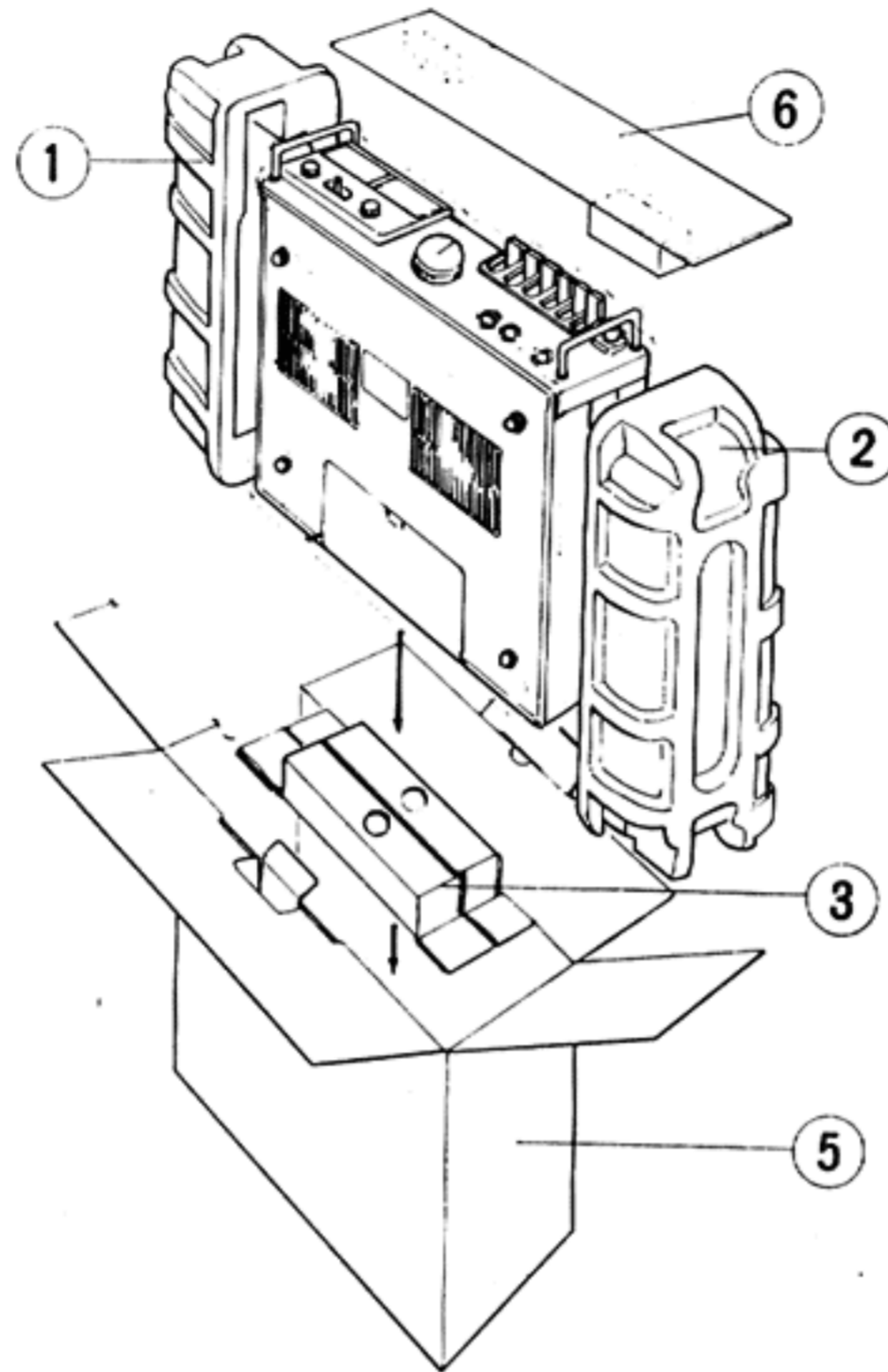

Fig. 45

Packing List

Ref. No.	Parts No.	Parts Name	Remarks	Q'ty
1~5	*TKB271323-0C	Packing Case Ass'y		1set
1	*TKC271104-01	Cushion (L)	Left	1
2	*TKC271105-01	" (R)	Right	1
3	*TKB271323-04	Battery Case		1
5	*TKB271323-08	Case		1
	T6800-00Q	Envelope	for Set	1
	AP4056A-046	"	for Power Cord	1
	AP4056A-077	"	for Instruction Book	1
6	*TKC304422-01	Cushion		1

JVC

VICTOR COMPANY OF JAPAN, LIMITED
RADIO & RECORDING MACHINE DIVISION